

Induction Motor

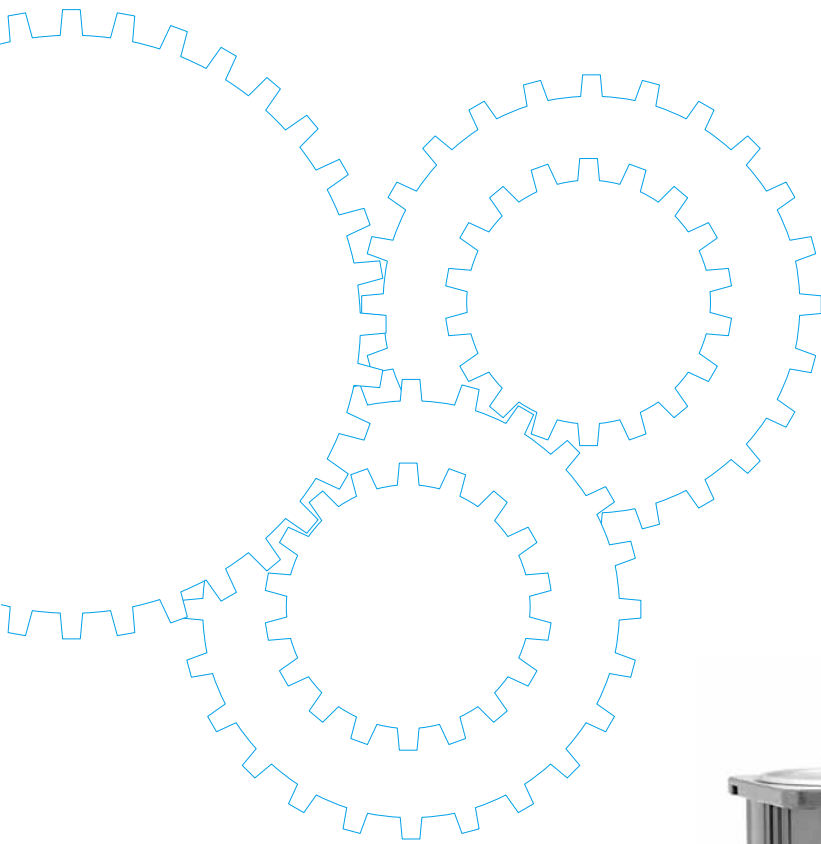

Contents

- Motor Overview B- 2
- Model list B- 4
- Product information for each model B- 8
- Gear head combination dimensions B-58
- Round shaft motor dimensions B-61

Outline of induction motor

Features

- It is fitted for continuous running in one direction. <Single-phase motor>
- Continuous time rating
- The motor with national specifications is of heatproof class 120 (E); the motor with specifications compliant with overseas standards is of heatproof class 130 (B).
- Because it is a capacitor-type induction motor, it has a high power factor and runs with a low noise level.

Note 1) The induction motor cannot make a quick-reversal run because of the torque acting in the opposite direction. Therefore stop the induction motor once, change the wire connections and make a reverse run.

Note 2) Induction motor start-stop operation must not exceed 6-cycles per minute or damage may occur.

Construction

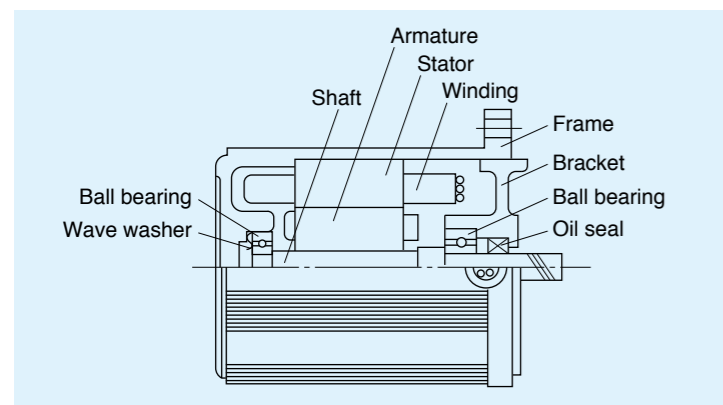

Characteristics

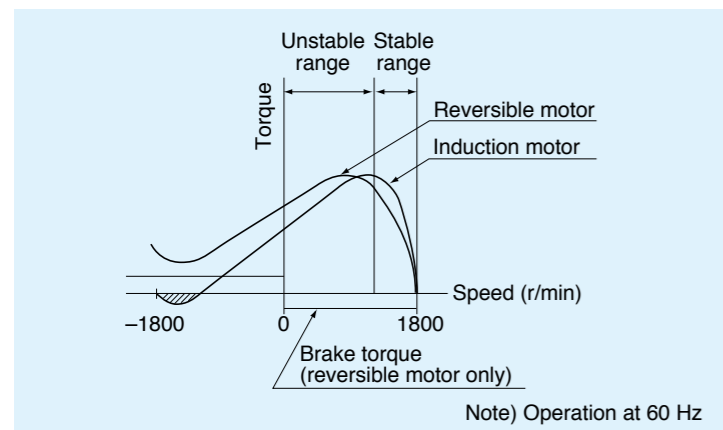

System configuration diagram

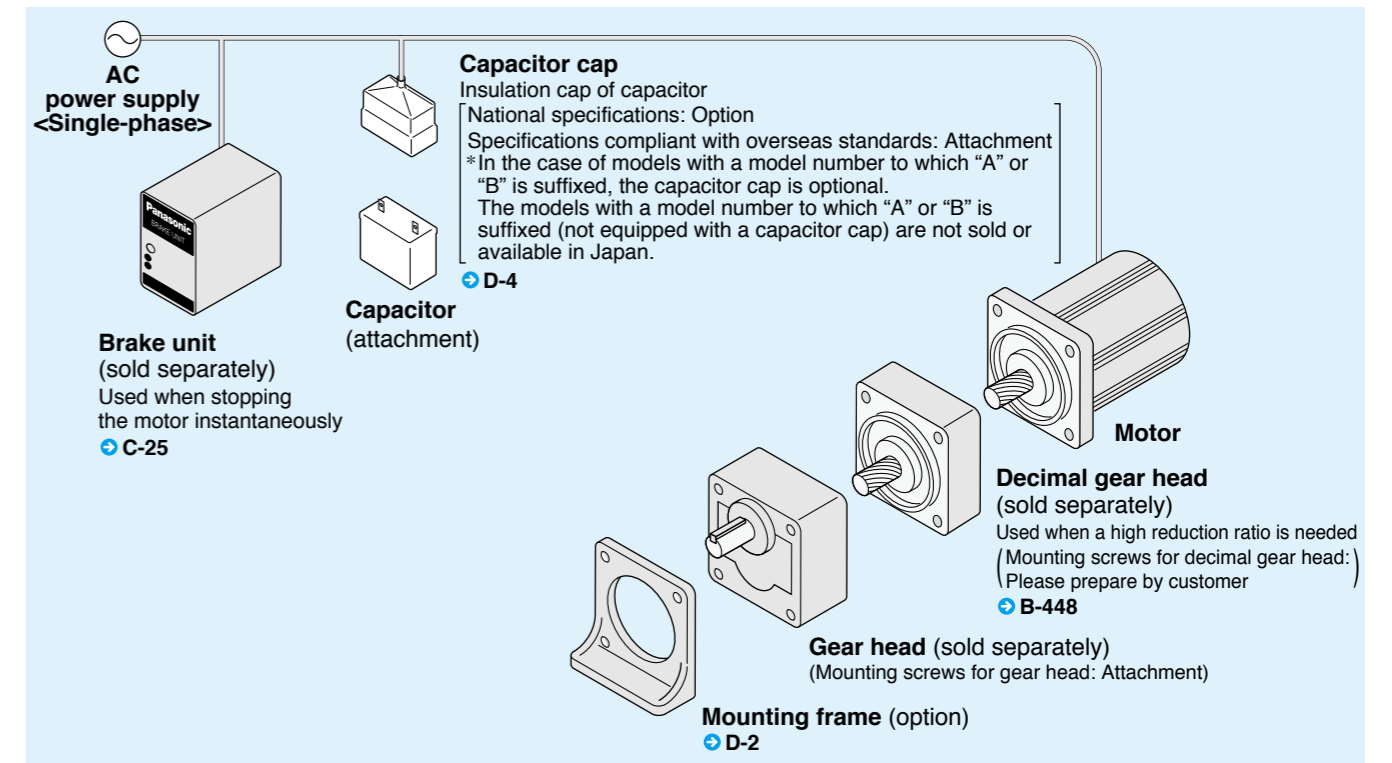

Coding system

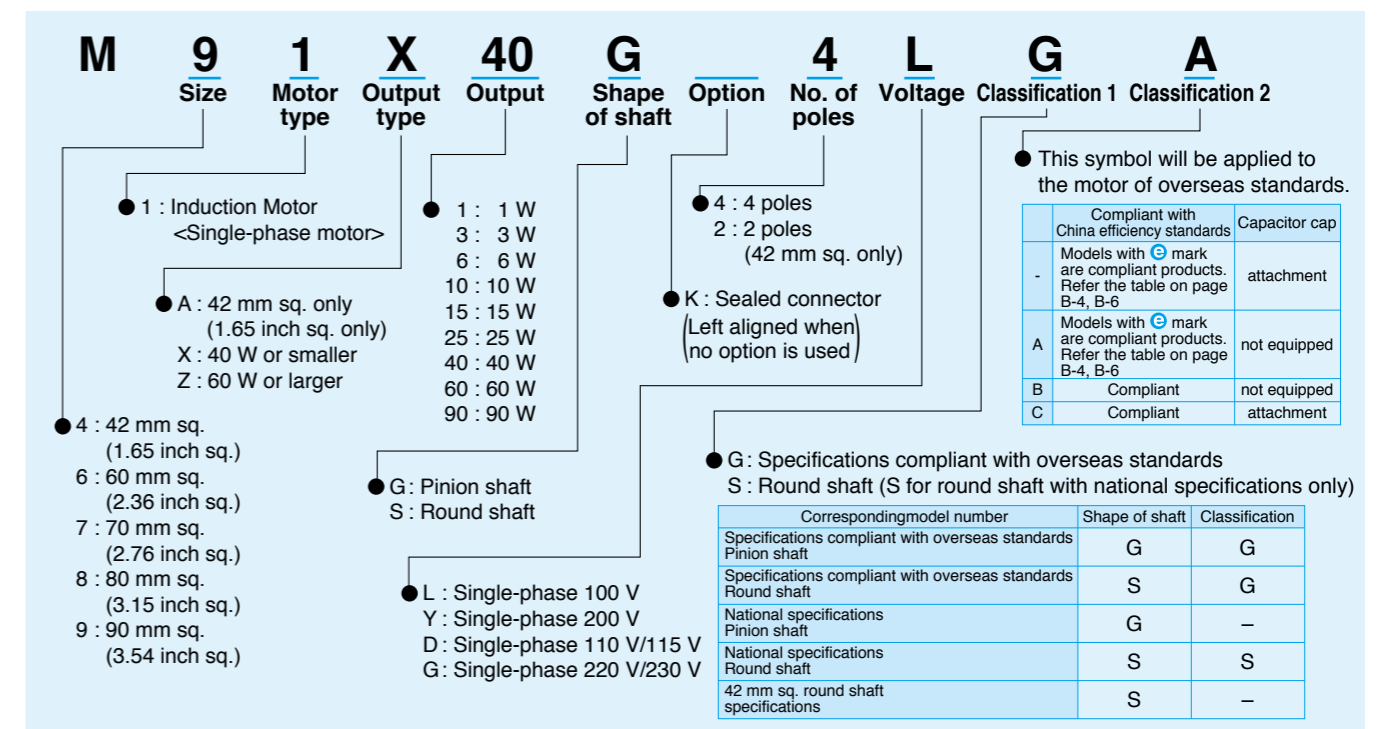

Fit tolerance

Fit tolerance symbol is used in the outside dimension diagram of motor and gear head. For further information, see "Fit tolerance" on page A-33.

Model list of induction motor

Pinion shaft motor

Applicable gear head

★ Motor compliant with overseas standards Ⓜ Motor compliant with China efficiency standards

Hinge attached

Size	Output (W)	Leadwire type			Sealed connector type			
		Model number	Specifications	Page	Model number	Specifications	Page	
42 mm sq. (1.65 inch sq.)	3	M41A3G2L	100 V	B- 8				
	1	M41A1G4L	100 V	B-10				
60 mm sq. (2.36 inch sq.)	3	M61X3G4L	100 V	B-12				
		M61X6G4L	100 V	B-14				
		M61X6G4Y	200 V	B-14				
		M61X6G4LG(A)	100 V ★	B-16				
		M61X6G4DG(A)	110 V/115 V ★	B-16				
		M61X6G4YG(A)	200 V ★	B-16				
70 mm sq. (2.76 inch sq.)	10	M71X10G4L	100 V	B-18				
		M71X10G4Y	200 V	B-18				
	15	M71X15G4L	100 V	B-20				
		M71X15G4Y	200 V	B-20				
		M71X15G4LG(A)	100 V ★	B-22				
		M71X15G4DG(A)	110 V/115 V ★	B-22				
		M71X15G4YG(A)	200 V ★	B-22				
		M71X15G4GG(A)	220 V/230 V ★ Ⓜ	B-22				
80 mm sq. (3.15 inch sq.)	15	M81X15G4L	100 V	B-24				
		M81X15G4Y	200 V	B-24				
	25	M81X25G4L	100 V	B-26	M81X25GK4L	100 V	B-42	
		M81X25G4Y	200 V	B-26	M81X25GK4Y	200 V	B-42	
		M81X25G4LG(A)	100 V ★	B-28	M81X25GK4LG(A)	100 V ★	B-44	
		M81X25G4DG(A)	110 V/115 V ★	B-28	M81X25GK4DG(A)	110 V/115 V ★	B-44	
		M81X25G4YG(A)	200 V ★	B-28	M81X25GK4YG(A)	200 V ★	B-44	
		M81X25G4GG(A)	220 V/230 V ★ Ⓜ	B-28	M81X25GK4GG(A)	220 V/230 V ★ Ⓜ	B-44	
90 mm sq. (3.54 inch sq.)	40	M91X40G4L	100 V	B-30	M91X40GK4L	100 V	B-46	
		M91X40G4Y	200 V	B-30	M91X40GK4Y	200 V	B-46	
		M91X40G4LG(A)	100 V ★	B-32	M91X40GK4LG(A)	100 V ★	B-48	
		M91X40G4DG(A)	110 V/115 V ★	B-32	M91X40GK4DG(A)	110 V/115 V ★	B-48	
		M91X40G4YG(A)	200 V ★	B-32	M91X40GK4YG(A)	200 V ★	B-48	
		M91X40G4GG(A)	220 V/230 V ★ Ⓜ	B-32	M91X40GK4GG(A)	220 V/230 V ★ Ⓜ	B-48	
		60	M91Z60G4L	100 V	B-34	M91Z60GK4L	100 V	B-50
			M91Z60G4Y	200 V	B-34	M91Z60GK4Y	200 V	B-50
	M91Z60G4LG(A)		100 V ★	B-36	M91Z60GK4LG(A)	100 V ★	B-52	
	M91Z60G4DG(A)		110 V/115 V ★	B-36	M91Z60GK4DG(A)	110 V/115 V ★	B-52	
	M91Z60G4YG(A)		200 V ★	B-36	M91Z60GK4YG(A)	200 V ★	B-52	
	M91Z60G4GG(A)		220 V/230 V ★	B-36	M91Z60GK4GG(A)	220 V/230 V ★	B-52	
	M91Z60G4GGB		220 V/230 V ★ Ⓜ	B-36	M91Z60GK4GGB	220 V/230 V ★ Ⓜ	B-52	
	M91Z60G4GGC		220 V/230 V ★ Ⓜ	B-36	M91Z60GK4GGC	220 V/230 V ★ Ⓜ	B-52	
	90	M91Z90G4L	100 V	B-38	M91Z90GK4L	100 V	B-54	
		M91Z90G4Y	200 V	B-38	M91Z90GK4Y	200 V	B-54	
M91Z90G4LG(A)		100 V ★	B-40	M91Z90GK4LG(A)	100 V ★	B-56		
M91Z90G4DG(A)		110 V/115 V ★	B-40	M91Z90GK4DG(A)	110 V/115 V ★	B-56		
M91Z90G4YG(A)		200 V ★	B-40	M91Z90GK4YG(A)	200 V ★	B-56		
M91Z90G4GG(A)		220 V/230 V ★	B-40	M91Z90GK4GG(A)	220 V/230 V ★	B-56		
M91Z90G4GGB		220 V/230 V ★ Ⓜ	B-40	M91Z90GK4GGB	220 V/230 V ★ Ⓜ	B-56		
M91Z90G4GGC		220 V/230 V ★ Ⓜ	B-40	M91Z90GK4GGC	220 V/230 V ★ Ⓜ	B-56		

* The models with a motor model number to which "A" or "B" is suffixed are not equipped with a capacitor cap.
The models with a motor model number to which "A" or "B" is suffixed are not sold or available in Japan.

Standard gear head			High torque gear head	Right-angle gear head	Gear head -Inch (U.S.A.)	Decimal gear head
Ball bearing	Metal bearing	Ball and metal bearing				
—	—	M4G□F	—	—	—	—
MX6G□BA MX6G□B	MX6G□MA MX6G□M	—	—	—	MX6G□BU	MX6G10XB
MX7G□BA MX7G□B	MX7G□MA MX7G□M	—	—	—	MX7G□BU	MX7G10XB
MX8G□B	MX8G□M	—	—	—	MX8G□BU	MX8G10XB
MX9G□B	MX9G□M	—	—	MX9G□R	MX9G□BU	MX9G10XB
MZ9G□B	—	—	MR9G□B	—	—	—
MY9G□B	—	—	—	MZ9G□R	MZ9G□BU	MZ9G10XB
			MP9G□B			

* Refer to page B-444 for dimensions and permissible torque of high torque gear head.
Refer to page B-446 for dimensions and permissible torque of right-angle gear head.
Refer to page B-451 for dimensions and permissible torque of gear head -Inch (U.S.A.).
Refer to page B-448 for dimensions of decimal gear head.

Model list of induction motor

Round shaft motor

★ Motor compliant with overseas standards Ⓜ Motor compliant with China efficiency standards cRUus CE Ⓞ
 Ⓢ Electrical Appliance and Material Safety Law

Size	Output (W)	Leadwire type		Sealed connector type			
		Model number	Specifications	Model number	Specifications		
42 mm sq. (1.65 inch sq.)	3	M41A3S2L	100 V				
	1	M41A1S4L	100 V				
60 mm sq. (2.36 inch sq.)	3	M61X3S4LS	100 V				
		M61X6S4LS	100 V				
		M61X6S4YS	200 V				
		M61X6S4LG(A)	100 V	★			
		M61X6S4DG(A)	110 V/115 V	★			
		M61X6S4YG(A)	200 V	★			
70 mm sq. (2.76 inch sq.)	10	M71X10S4LS	100 V				
		M71X10S4YS	200 V				
	15	M71X15S4LS	100 V				
		M71X15S4YS	200 V				
		M71X15S4LG(A)	100 V	★			
		M71X15S4DG(A)	110 V/115 V	★			
		M71X15S4YG(A)	200 V	★			
		M71X15S4GG(A)	220 V/230 V	★ Ⓜ			
80 mm sq. (3.15 inch sq.)	15	M81X15S4LS	100 V				
		M81X15S4YS	200 V				
	25	M81X25S4LS	100 V		M81X25SK4LS	100 V Ⓢ	
		M81X25S4YS	200 V		M81X25SK4YS	200 V Ⓢ	
		M81X25S4LG(A)	100 V	★	M81X25SK4LG(A)	100 V ★ Ⓢ	
		M81X25S4DG(A)	110 V/115 V	★	M81X25SK4DG(A)	110 V/115 V ★	
		M81X25S4YG(A)	200 V	★	M81X25SK4YG(A)	200 V ★ Ⓢ	
		M81X25S4GG(A)	220 V/230 V	★ Ⓜ	M81X25SK4GG(A)	220 V/230 V ★ Ⓜ Ⓢ	
90 mm sq. (3.54 inch sq.)	40	M91X40S4LS	100 V		M91X40SK4LS	100 V Ⓢ	
		M91X40S4YS	200 V		M91X40SK4YS	200 V Ⓢ	
		M91X40S4LG(A)	100 V	★	M91X40SK4LG(A)	100 V ★ Ⓢ	
		M91X40S4DG(A)	110 V/115 V	★	M91X40SK4DG(A)	110 V/115 V ★	
		M91X40S4YG(A)	200 V	★	M91X40SK4YG(A)	200 V ★ Ⓢ	
		M91X40S4GG(A)	220 V/230 V	★ Ⓜ	M91X40SK4GG(A)	220 V/230 V ★ Ⓜ Ⓢ	
	60	M91Z60S4LS	100 V		M91Z60SK4LS	100 V Ⓢ	
		M91Z60S4YS	200 V		M91Z60SK4YS	200 V Ⓢ	
		M91Z60S4LG(A)	100 V	★	M91Z60SK4LG(A)	100 V ★ Ⓢ	
		M91Z60S4DG(A)	110 V/115 V	★	M91Z60SK4DG(A)	110 V/115 V ★	
		M91Z60S4YG(A)	200 V	★	M91Z60SK4YG(A)	200 V ★ Ⓢ	
		M91Z60S4GG(A)	220 V/230 V	★	M91Z60SK4GG(A)	220 V/230 V ★	
		M91Z60S4GGB	220 V/230 V	★ Ⓜ	M91Z60SK4GGB	220 V/230 V ★ Ⓜ Ⓢ	
		M91Z60S4GGC	220 V/230 V	★ Ⓜ	M91Z60SK4GGC	220 V/230 V ★ Ⓜ Ⓢ	
		90	M91Z90S4LS	100 V		M91Z90SK4LS	100 V Ⓢ
			M91Z90S4YS	200 V		M91Z90SK4YS	200 V Ⓢ
			M91Z90S4LG(A)	100 V	★	M91Z90SK4LG(A)	100 V ★ Ⓢ
			M91Z90S4DG(A)	110 V/115 V	★	M91Z90SK4DG(A)	110 V/115 V ★
M91Z90S4YG(A)	200 V		★	M91Z90SK4YG(A)	200 V ★ Ⓢ		
M91Z90S4GG(A)	220 V/230 V		★	M91Z90SK4GG(A)	220 V/230 V ★		
M91Z90S4GGB	220 V/230 V	★ Ⓜ	M91Z90SK4GGB	220 V/230 V ★ Ⓜ Ⓢ			
M91Z90S4GGC	220 V/230 V	★ Ⓜ	M91Z90SK4GGC	220 V/230 V ★ Ⓜ Ⓢ			

* The specifications and wire connections of the round shaft motor are the same as those of the pinion shaft motor.

Dimensional outline drawing → Page B-61.

* The models with a motor model number to which "A" or "B" is suffixed are not equipped with a capacitor cap.
 The models with a motor model number to which "A" or "B" is suffixed are not sold or available in Japan.

Specifications

Size	Motor model No.	Number of pole (P)	Output (W)	Voltage (V)	Frequency (Hz)	Rating (min)	Rating			Starting current (A)	Starting torque N·m (oz-in)	Capacitor (μF) (rated voltage)
							Input (W)	Current (A)	Speed (r/min)			
42 mm sq.	M41A3G2L	2	3	100	50	Cont.	10	0.10	2625	0.011 (1.6)	0.15	1.5 (200 V)
					60		9	0.10	3250	0.009 (1.3)	0.15	

* The specifications and wire connections of the round shaft motor are the same as those of the pinion shaft type. For the dimensional outline drawing, refer to page B-61.

Permissible torque at output shaft of gear head

* The speed shown below is a calculated value based on the synchronous rotational speed. Depending on the load, the speed is less than the indicated value by 2% to 20%.

Unit of permissible torque: upper (mN·m) / lower (lb-in)

Reduction ratio	Unit of permissible torque: upper (mN·m) / lower (lb-in)																				
	3	3.6	5	6	7.5	9	12.5	15	18	25	30	36	50	60	75	90	100	120	150	180	
Speed (r/min)	50 Hz	1000	833	600	500	400	333	240	200	167	120	100	83.3	60	50	40	33.3	30	25	20	16.7
	60 Hz	1200	1000	720	600	480	400	288	240	200	144	120	100	72	60	48	40	36	30	24	20
Applicable gear head	M4GA3F to M4GA180F (metal+ball bearing)	50 Hz	28 (0.248)	34 (0.301)	47 (0.416)	57 (0.504)	71 (0.628)	84 (0.743)	98 (0.867)	127 (1.12)	157 (1.39)	186 (1.65)	225 (1.99)	274 (2.43)	382 (3.38)	461 (4.08)	490 (4.34)				
		60 Hz	24 (0.212)	28 (0.248)	39 (0.345)	47 (0.416)	59 (0.522)	71 (0.628)	81 (0.717)	98 (0.867)	127 (1.12)	176 (1.56)	186 (1.65)	225 (1.99)	313 (2.77)	382 (3.38)	490 (4.34)				
Rotational direction		Same as motor rotational direction						Reverse to motor rotational direction			Same as motor rotational direction						Reverse to motor rotational direction				

Motor (dimensions)

M41A3G2L 2P 3 W 100 V

Scale: 1/3, Unit: mm (inch)

Mass 0.3 kg 0.66 lb	Spur gear	Module 0.4	Number of teeth 10
---------------------------	-----------	---------------	-----------------------

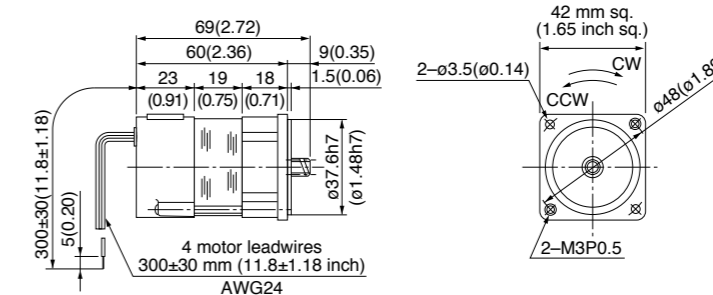

Capacitor (dimensions) [attachment]

Unit: mm (inch)

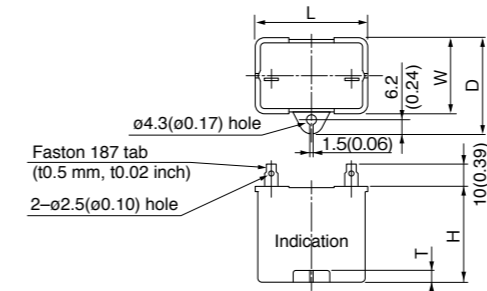

Capacitor cap (dimensions) [option]

Unit: mm (inch)

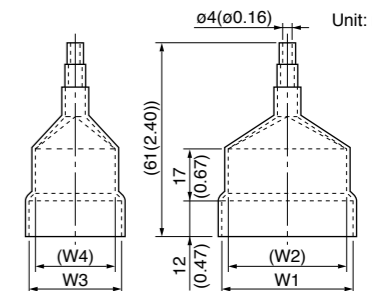

Capacitor dimension list

Unit: upper (mm) / lower (inch)

Model number of motor	Model number of capacitor (attachment)	L	W	D	H	T	Capacitor cap (option)	W1	W2	W3	W4
M41A3G2L	M0PC1.5M20	39.5 (1.56)	16 (0.63)	26.5 (1.04)	30.5 (1.20)	4 (0.16)	M0PC3917	39.5 (1.56)	37.5 (1.48)	17 (0.67)	15 (0.59)

* Capacitors (single item) can also be purchased.

Connection diagram

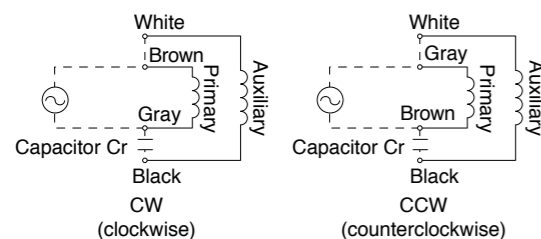

Speed-torque characteristics

M41A3G2L

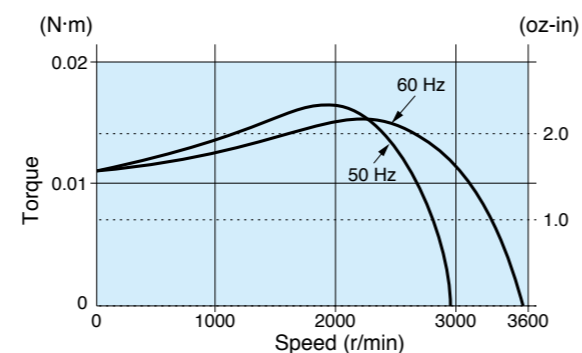

* Please read your User's manual carefully so that you will understand the operation and safety precautions before attempting to operate the system.

- Features B-2
- System configuration B-3
- Coding system B-3
- Model list B-4

Gear head (dimensions)

Scale: 1/3, Unit: mm (inch)

M4GA□F (ball + metal bearing) Mass 0.2 kg(0.44 lb): Output shaft D cut

* In the case of 42 mm sq. (1.65 inch sq.), a ball bearing is used for the output shaft only.

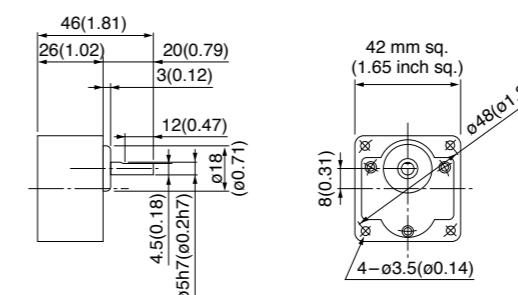

(Note) Because the dimensions may be subject to change, also check the determinate dimensions if the gear head is to be used for design.

- Gear head combination B-58
- Round shaft motor B-61
- Decimal gear head B-448
- Gear head -inch (U.S.A.) B-449
- Controls C-4
- Option D-2

• Specifications

Size	Motor model No.	Number of pole (P)	Output (W)	Voltage (V)	Frequency (Hz)	Rating (min)	Rating				Starting current (A)	Starting torque N-m (oz-in)	Capacitor (μF) (rated voltage)
							Input (W)	Current (A)	Speed (r/min)	Torque N-m (oz-in)			
42 mm sq.	M41A1G4L	4	1	100	50	Cont.	10	0.11	1175	0.0078 (1.10)	0.11	0.015 (2.12)	1.3 (200 V)
					60		10	0.11	1575	0.0059 (0.84)	0.11	0.016 (2.27)	

* The specifications and wire connections of the round shaft motor are the same as those of the pinion shaft type. For the dimensional outline drawing, refer to page B-61.

• Permissible torque at output shaft of gear head

* The speed shown below is a calculated value based on the synchronous rotational speed. Depending on the load, the speed is less than the indicated value by 2% to 20%.

Unit of permissible torque: upper (mN·m) / lower (lb-in)

Reduction ratio	Unit of permissible torque: upper (mN·m) / lower (lb-in)																					
	3	3.6	5	6	7.5	9	12.5	15	18	25	30	36	50	60	75	90	100	120	150	180		
Speed (r/min)	50 Hz	500	416.7	300	250	200	166.7	120	100	83.3	60	50	41.7	30	25	20	16.7	15	12.5	10	8.3	
	60 Hz	600	500	360	300	240	200	144	120	100	72	60	50	36	30	24	20	18	15	12	10	
Applicable gear head	M4GA3F to M4GA180F (metal+ball bearing)	50 Hz	23 (0.20)	27 (0.24)	37 (0.33)	45 (0.40)	56 (0.50)	67 (0.59)	84 (0.74)	98 (0.87)	118 (1.04)	147 (1.30)	176 (1.56)	216 (1.91)	303 (2.68)	363 (3.21)	411 (3.64)	490 (4.34)				
		60 Hz	19 (0.17)	23 (0.20)	31 (0.27)	37 (0.33)	47 (0.42)	56 (0.50)	77 (0.68)	84 (0.74)	98 (0.87)	137 (1.21)	147 (1.30)	176 (1.56)	245 (2.17)	303 (2.68)	382 (3.39)	411 (3.64)	490 (4.34)			
Rotational direction		Same as motor rotational direction						Reverse to motor rotational direction			Same as motor rotational direction						Reverse to motor rotational direction					

Connection diagram

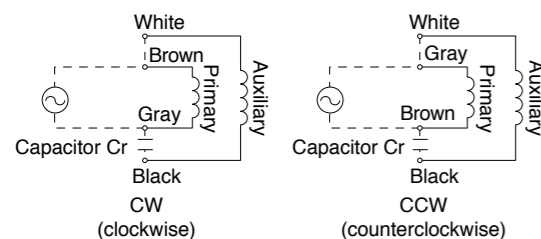

Speed-torque characteristics

M41A1G4L

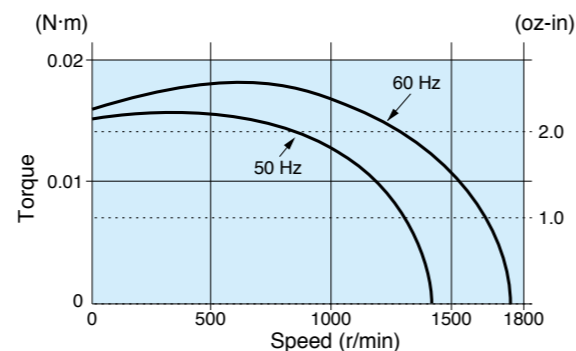

* Please read your User's manual carefully so that you will understand the operation and safety precautions before attempting to operate the system.

Features B-2 System configuration B-3 Coding system B-3 Model list B-4

Motor (dimensions)

Scale: 1/3, Unit: mm (inch)

M41A1G4L 4P 1 W 100 V

Mass 0.3 kg (0.66 lb)
Spur gear
Module 0.4
Number of teeth 10

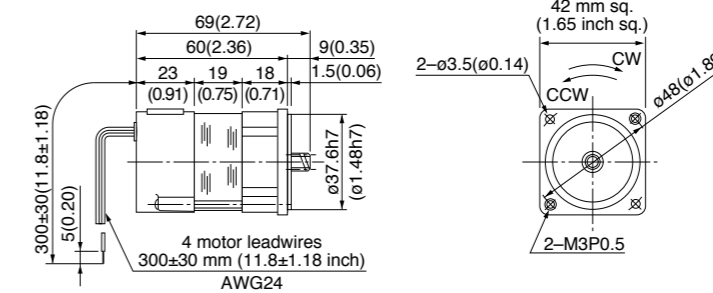

Capacitor (dimensions) [attachment]

Unit: mm (inch)

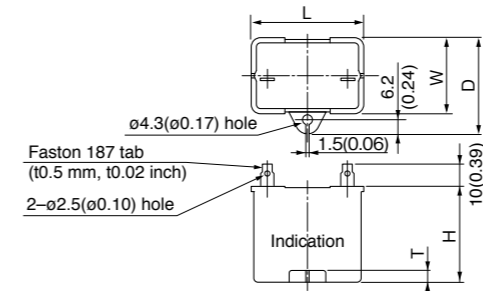

Capacitor cap (dimensions) [option]

Unit: mm (inch)

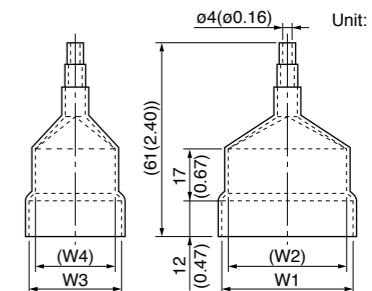

• Capacitor dimension list Unit: upper (mm) / lower (inch)

Model number of motor	Model number of capacitor (attachment)	L	W	D	H	T	Capacitor cap (option)	W1	W2	W3	W4
M41A1G4L	M0PC1.3M20	39.5 (1.56)	16 (0.63)	26.5 (1.04)	30.5 (1.20)	4 (0.16)	M0PC3917	39.5 (1.56)	37.5 (1.48)	17 (0.67)	15 (0.59)

* Capacitors (single item) can also be purchased.

Gear head (dimensions)

Scale: 1/3, Unit: mm (inch)

M4GA□F (ball + metal bearing) Mass 0.2 kg(0.44 lb): Output shaft D cut

* In the case of 42 mm sq. (1.65 inch sq.), a ball bearing is used for the output shaft only.

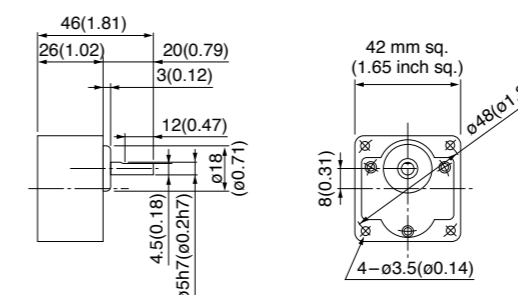

(Note) Because the dimensions may be subject to change, also check the determinate dimensions if the gear head is to be used for design.

Gear head combination B-58 Round shaft motor B-61 Decimal gear head B-448 Gear head -inch (U.S.A.) B-449 Controls C-4 Option D-2

Specifications

Size	Motor model No.	Number of pole (P)	Output (W)	Voltage (V)	Frequency (Hz)	Rating (min)	Rating			Starting current (A)	Starting torque N·m (oz-in)	Capacitor (μF) (rated voltage)
							Input (W)	Current (A)	Speed (r/min)			
60 mm sq.	M61X3G4L	4	3	100	50	Cont.	15	0.15	1250	0.022 (3.1)	0.18	2.0 (200 V)
					60		15	0.15	1575	0.018 (2.5)	0.19	

* The specifications and wire connections of the round shaft motor are the same as those of the pinion shaft type. For the dimensional outline drawing, refer to page B-61.

Permissible torque at output shaft of gear head

* The speed shown below is a calculated value based on the synchronous rotational speed. Depending on the load, the speed is less than the indicated value by 2% to 20%.
* The part number of reduction gear ratio less than 1/25 is MX6G□BA (MA).

Unit of permissible torque: upper (N·m) / lower (lb-in)

Reduction ratio	Unit of permissible torque: upper (N·m) / lower (lb-in)																							
	3	3.6	5	6	7.5	9	10	12.5	15	18	20	25	30	36	50	60	75	90	100	120	150	180		
Speed (r/min)	50 Hz		60 Hz		50 Hz		60 Hz		50 Hz		60 Hz		50 Hz		60 Hz		50 Hz		60 Hz		50 Hz		60 Hz	
Applicable gear head	MX6G3BA to MX6G180B (ball bearing)											MX6G3MA to MX6G180M (metal bearing)												
	50 Hz											60 Hz												
Rotational direction	Same as motor rotational direction											Reverse to motor rotational direction												

Permissible torque at output shaft of gear head using decimal gear head

* For external dimensions of the decimal gear head, refer to page B-448.

Applicable gear head		Reduction ratio	Permissible torque													
Bearing	Decimal gear head		Speed (r/min)	50 Hz	60 Hz	200	250	300	360	500	600	750	900	1000	1200	1500
MX6G□BA (ball bearing)	MX6G10XB	Speed (r/min)	50 Hz	60 Hz	7.5	6	5	4.2	3	2.5	2	1.7	1.5	1.3	1	0.8
MX6G□B (bearing)			50 Hz	60 Hz	9	7.2	6	5	3.6	3	2.4	2	1.8	1.5	1.2	1
MX6G□MA (metal bearing)		Permissible torque	50 Hz	60 Hz	2.45	2.45	2.45	2.45	2.45	2.45	2.45	2.45	2.45	2.45	2.45	2.45
MX6G□M (bearing)			50 Hz	60 Hz	(21.7)	(21.7)	(21.7)	(21.7)	(21.7)	(21.7)	(21.7)	(21.7)	(21.7)	(21.7)	(21.7)	(21.7)
Rotational direction		Same as motor rotational direction / Reverse to motor rotational direction														

Connection diagram

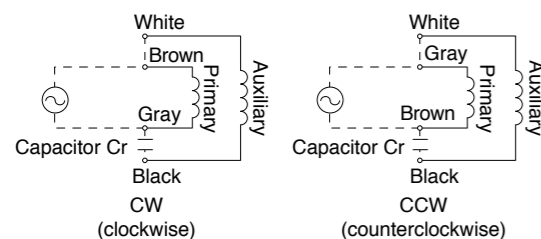

Speed-torque characteristics

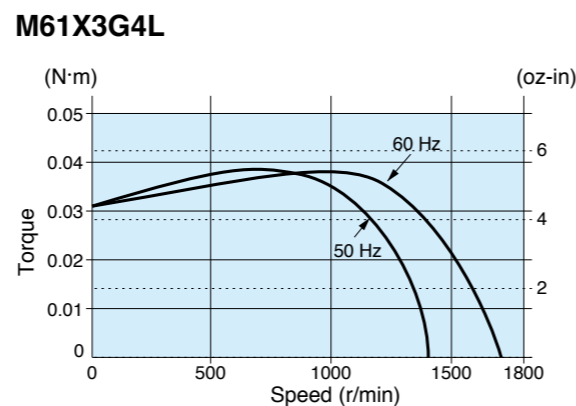

* Please read your User's manual carefully so that you will understand the operation and safety precautions before attempting to operate the system.

Features B-2 System configuration B-3 Coding system B-3 Model list B-4

Motor (dimensions)

Scale: 1/3, Unit: mm (inch)

M61X3G4L 4P 3 W 100 V

Mass 0.56 kg (1.23 lb)
Helical gear
Module 0.5
Number of teeth 6

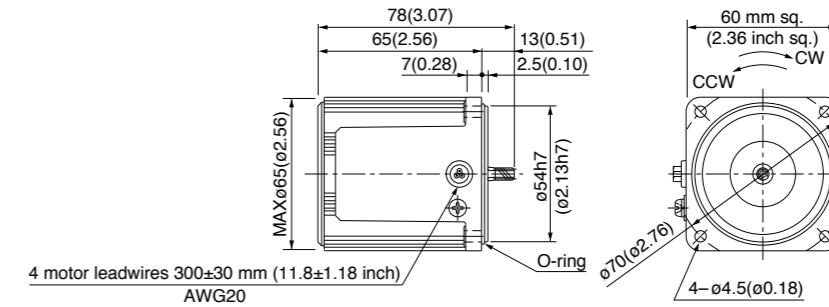

Capacitor (dimensions) [attachment]

Unit: mm (inch)

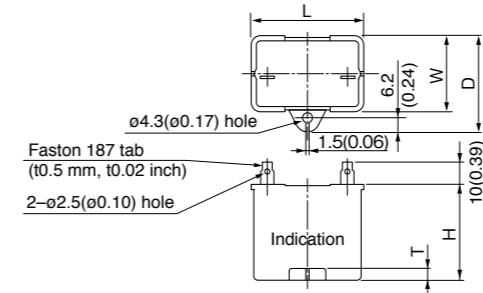

Capacitor cap (dimensions) [option]

Unit: mm (inch)

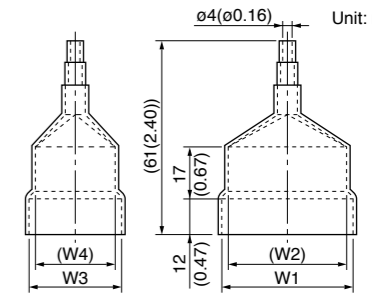

Capacitor dimension list

Unit: upper (mm) / lower (inch)

Model number of motor	Model number of capacitor (attachment)	L	W	D	H	T	Capacitor cap (option)	W1	W2	W3	W4
M61X3G4L	M0PC2M20	39.5 (1.56)	16 (0.63)	26.5 (1.04)	30.5 (1.20)	4 (0.16)	M0PC3917	39.5 (1.56)	37.5 (1.48)	17 (0.67)	15 (0.59)

* Capacitors (single item) can also be purchased.

Gear head (dimensions)

Scale: 1/3, Unit: mm (inch)

< □ is 25 or less >
MX6G□BA (ball bearing) Mass 0.24 kg(0.53 lb): Output shaft D cut
MX6G□MA (metal bearing) Mass 0.24 kg(0.53 lb): Output shaft D cut
 < □ is 30 or more >
MX6G□B (ball bearing) Mass 0.3 kg(0.66 lb): Output shaft D cut
MX6G□M (metal bearing) Mass 0.3 kg(0.66 lb): Output shaft D cut

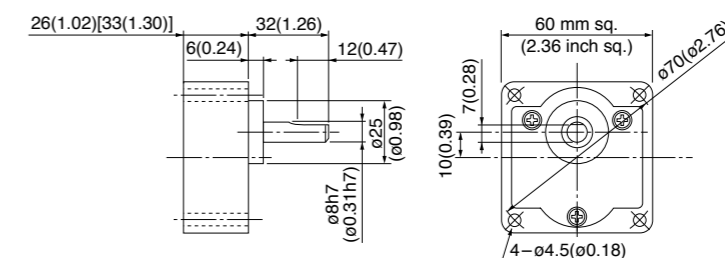

* Figures in [] represent the dimensions of MX6G□B (M) (1/30 or larger reduction ratio).

(Note) Because the dimensions may be subject to change, also check the determinate dimensions if the gear head is to be used for design.

Gear head combination B-58 Round shaft motor B-61 Decimal gear head B-448 Gear head -inch (U.S.A.) B-449 Controls C-4 Option D-2

Specifications

Size	Motor model No.	Number of pole (P)	Output (W)	Voltage (V)	Frequency (Hz)	Rating (min)	Rating				Starting current (A)	Starting torque N-m (oz-in)	Capacitor (μF) (rated voltage)
							Input (W)	Current (A)	Speed (r/min)	Torque N-m (oz-in)			
60 mm sq.	M61X6G4L	4	6	100	50	Cont.	20	0.21	1250	0.048 (6.80)	0.30	0.049 (6.94)	2.5 (200 V)
							20	0.20	1575	0.038 (5.38)	0.30	0.049 (6.94)	
	M61X6G4Y	4	6	200	50	Cont.	20	0.11	1250	0.048 (6.80)	0.15	0.049 (6.94)	0.7 (400 V)
							20	0.10	1600	0.037 (5.24)	0.15	0.049 (6.94)	

* The specifications and wire connections of the round shaft motor are the same as those of the pinion shaft type. For the dimensional outline drawing, refer to page B-61.

Permissible torque at output shaft of gear head

* The speed shown below is a calculated value based on the synchronous rotational speed. Depending on the load, the speed is less than the indicated value by 2% to 20%.
* The part number of reduction gear ratio less than 1/25 is MX6G□BA (MA).

Unit of permissible torque: upper (N·m) / lower (lb-in)

Reduction ratio	Speed (r/min)																							
	50 Hz	60 Hz	3	3.6	5	6	7.5	9	10	12.5	15	18	20	25	30	36	50	60	75	90	100	120	150	180
MX6G3BA to MX6G180B (ball bearing)	0.098 (0.87)	0.12 (1.06)	0.16 (1.42)	0.19 (1.68)	0.25 (2.21)	0.29 (2.57)	0.33 (2.92)	0.40 (3.54)	0.49 (4.34)	0.59 (5.22)	0.66 (5.84)	0.79 (6.99)	0.95 (8.41)	1.18 (10.4)	1.57 (13.9)	1.86 (16.5)	2.25 (19.9)	2.45 (21.7)						
MX6G3MA to MX6G180M (metal bearing)	0.081 (0.72)	0.098 (0.87)	0.13 (1.15)	0.16 (1.42)	0.21 (1.86)	0.25 (2.21)	0.26 (2.30)	0.33 (2.92)	0.40 (3.54)	0.49 (4.34)	0.53 (4.69)	0.66 (5.84)	0.79 (6.99)	0.95 (8.41)	1.27 (11.2)	1.57 (13.9)	1.86 (16.5)	2.25 (19.9)						

Rotational direction: Same as motor rotational direction / Reverse to motor rotational direction

Permissible torque at output shaft of gear head using decimal gear head

* For external dimensions of the decimal gear head, refer to page B-448.

Applicable gear head	Reduction ratio	Speed (r/min)																						
		200	250	300	360	500	600	750	900	1000	1200	1500	1800											
MX6G□BA (ball bearing) MX6G□B (bearing) MX6G□MA (metal bearing) MX6G□M (bearing)	MX6G10XB	Permissible torque	2.45 (21.7)	2.45 (21.7)	2.45 (21.7)	2.45 (21.7)	2.45 (21.7)	2.45 (21.7)	2.45 (21.7)	2.45 (21.7)	2.45 (21.7)	2.45 (21.7)	2.45 (21.7)	2.45 (21.7)	2.45 (21.7)	2.45 (21.7)	2.45 (21.7)	2.45 (21.7)	2.45 (21.7)	2.45 (21.7)	2.45 (21.7)	2.45 (21.7)	2.45 (21.7)	2.45 (21.7)
		Rotational direction	Same as motor rotational direction / Reverse to motor rotational direction																					

Motor (dimensions)

Scale: 1/3, Unit: mm (inch)

M61X6G4L	4P 6 W 100 V
M61X6G4Y	4P 6 W 200 V

Mass	Helical gear	Module	Number of teeth
0.67 kg (1.48 lb)		0.5	6

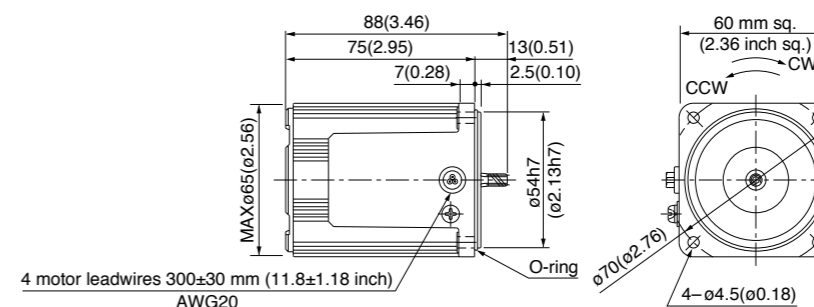

Capacitor (dimensions) [attachment]

Unit: mm (inch)

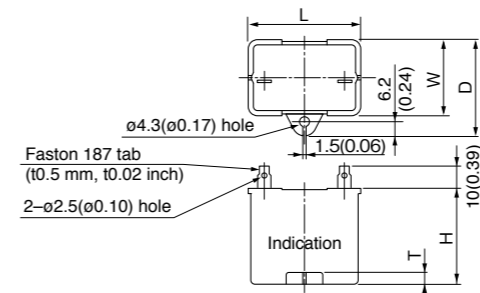

Capacitor cap (dimensions) [option]

Unit: mm (inch)

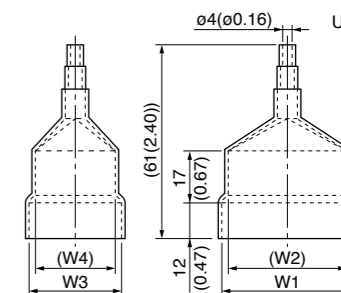

Capacitor dimension list

Unit: upper (mm) / lower (inch)

Model number of motor	Model number of capacitor (attachment)	L	W	D	H	T	Capacitor cap (option)	W1	W2	W3	W4
M61X6G4L	M0PC2.5M20	39.5 (1.56)	16 (0.63)	26.5 (1.04)	30.5 (1.20)	4 (0.16)	M0PC3917	39.5 (1.56)	37.5 (1.48)	17 (0.67)	15 (0.59)
M61X6G4Y	M0PC0.7M40	39.5 (1.56)	16.2 (0.64)	27 (1.06)	27 (1.06)	4 (0.16)	M0PC3917	39.5 (1.56)	37.5 (1.48)	17 (0.67)	15 (0.59)

* Capacitors (single item) can also be purchased.

Connection diagram

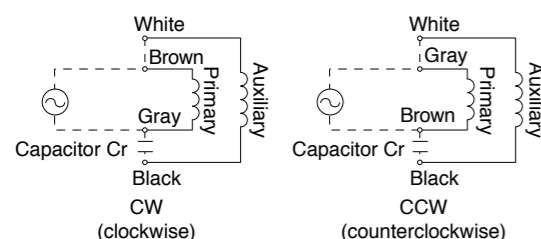

Speed-torque characteristics

M61X6G4L

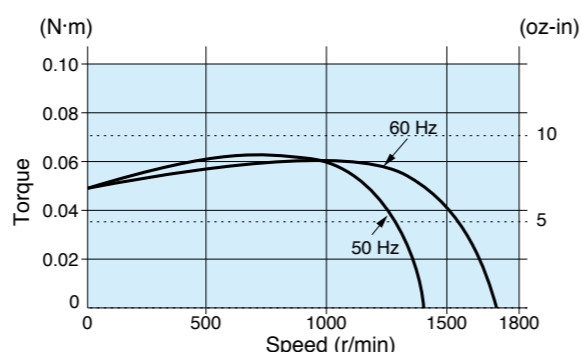

* Please read your User's manual carefully so that you will understand the operation and safety precautions before attempting to operate the system.

Features B-2 System configuration B-3 Coding system B-3 Model list B-4

Gear head (dimensions)

Scale: 1/3, Unit: mm (inch)

< □ is 25 or less >
MX6G□BA (ball bearing) Mass 0.24 kg(0.53 lb): Output shaft D cut
MX6G□MA (metal bearing) Mass 0.24 kg(0.53 lb): Output shaft D cut
 < □ is 30 or more >
MX6G□B (ball bearing) Mass 0.3 kg(0.66 lb): Output shaft D cut
MX6G□M (metal bearing) Mass 0.3 kg(0.66 lb): Output shaft D cut

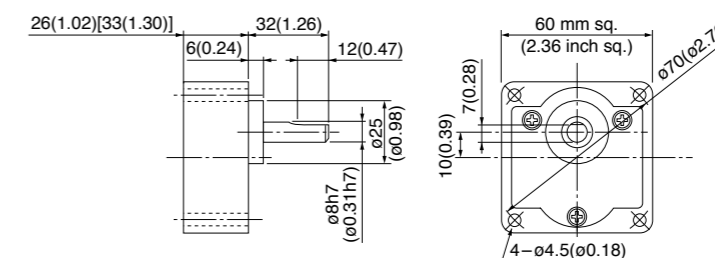

* Figures in [] represent the dimensions of MX6G□B (M) (1/30 or larger reduction ratio).

(Note) Because the dimensions may be subject to change, also check the determinate dimensions if the gear head is to be used for design.

Gear head combination B-58 Round shaft motor B-61 Decimal gear head B-448 Gear head -inch (U.S.A.) B-449 Controls C-4 Option D-2

Specifications

Size	Motor model No.	Number of pole (P)	Output (W)	Voltage (V)	Frequency (Hz)	Rating (min)	Rating				Starting current (A)	Starting torque N-m (oz-in)	Capacitor (μF) (rated voltage)
							Input (W)	Current (A)	Speed (r/min)	Torque N-m (oz-in)			
70 mm sq.	M71X15G4L	4	15	100	50	Cont.	34	0.37	1250	0.11 (15.6)	0.61	0.077 (10.9)	4 (200 V)
							33	0.33	1575	0.088 (12.5)	0.57	0.077 (10.9)	
	M71X15G4Y	4	15	200	60	Cont.	33	0.18	1300	0.11 (15.6)	0.30	0.077 (10.9)	1 (400 V)
							34	0.17	1600	0.088 (12.5)	0.29	0.077 (10.9)	

* The specifications and wire connections of the round shaft motor are the same as those of the pinion shaft type. For the dimensional outline drawing, refer to page B-61.

Permissible torque at output shaft of gear head

* The speed shown below is a calculated value based on the synchronous rotational speed. Depending on the load, the speed is less than the indicated value by 2% to 20%.
* The part number of reduction gear ratio less than 1/25 is MX7G□BA (MA).

Unit of permissible torque: upper (N·m) / lower (lb-in)

Reduction ratio	Speed (r/min)																							
	50 Hz	60 Hz	3	3.6	5	6	7.5	9	10	12.5	15	18	20	25	30	36	50	60	75	90	100	120	150	180
MX7G3BA to MX7G180B (ball bearing)	0.24 (2.12)	0.28 (2.48)	0.39 (3.45)	0.47 (4.16)	0.59 (5.22)	0.71 (6.28)	0.80 (7.08)	0.98 (8.67)	1.18 (10.4)	1.37 (12.1)	1.57 (13.9)	1.86 (16.5)	2.25 (19.9)	2.74 (24.3)	3.82 (33.8)	4.61 (40.8)	4.90 (43.4)							
MX7G3MA to MX7G180M (metal bearing)	0.20 (1.77)	0.24 (2.12)	0.32 (2.83)	0.39 (3.45)	0.49 (4.34)	0.59 (5.22)	0.66 (5.84)	0.81 (7.17)	0.98 (8.67)	1.18 (10.4)	1.27 (11.2)	1.57 (13.9)	1.86 (16.5)	2.25 (19.9)	3.23 (28.6)	3.82 (33.8)	4.80 (42.5)							
Rotational direction	Same as motor rotational direction											Reverse to motor rotational direction												

Permissible torque at output shaft of gear head using decimal gear head

* For external dimensions of the decimal gear head, refer to page B-448.

Applicable gear head	Reduction ratio	Speed (r/min)																						
		200	250	300	360	500	600	750	900	1000	1200	1500	1800											
MX7G□BA (ball bearing) MX7G□B (bearing) MX7G□MA (metal bearing) MX7G□M (bearing)	MX7G10XB	Permissible torque	4.90 (43.4)	4.90 (43.4)	4.90 (43.4)	4.90 (43.4)	4.90 (43.4)	4.90 (43.4)	4.90 (43.4)	4.90 (43.4)	4.90 (43.4)	4.90 (43.4)	4.90 (43.4)	4.90 (43.4)	4.90 (43.4)	4.90 (43.4)	4.90 (43.4)	4.90 (43.4)	4.90 (43.4)	4.90 (43.4)	4.90 (43.4)	4.90 (43.4)	4.90 (43.4)	4.90 (43.4)
		Rotational direction	Same as motor rotational direction						Reverse to motor rotational direction															

Motor (dimensions)

M71X15G4L	4P 15 W 100 V
M71X15G4Y	4P 15 W 200 V

Scale: 1/3, Unit: mm (inch)

Mass	Helical gear	Module	Number of teeth
1.1 kg 2.43 lb		0.5	7

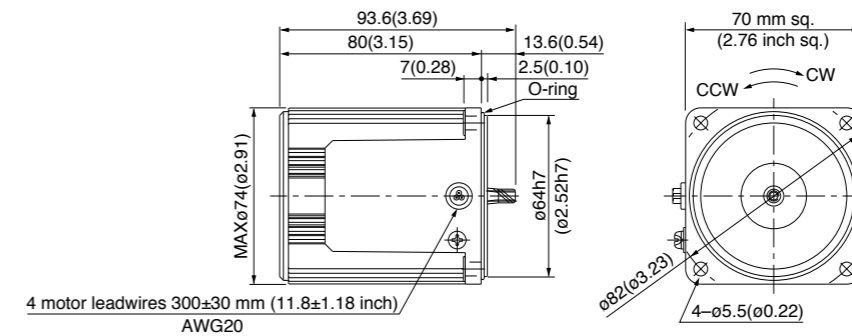

Capacitor (dimensions) [attachment]

Unit: mm (inch)

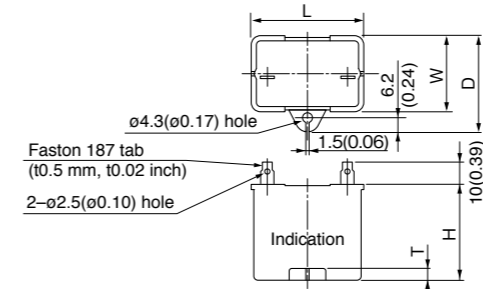

Capacitor cap (dimensions) [option]

Unit: mm (inch)

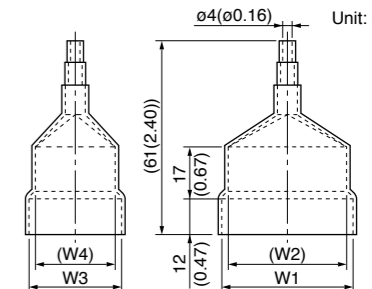

Capacitor dimension list

Unit: upper (mm) / lower (inch)

Model number of motor	Model number of capacitor (attachment)	L	W	D	H	T	Capacitor cap (option)	W1	W2	W3	W4
M71X15G4L	M0PC4M20	39.5 (1.56)	16 (0.63)	26.5 (1.04)	30.5 (1.20)	4 (0.16)	M0PC3917	39.5 (1.56)	37.5 (1.48)	17 (0.67)	15 (0.59)
M71X15G4Y	M0PC1M40	39.5 (1.56)	16.2 (0.64)	27 (1.06)	27 (1.06)	4 (0.16)	M0PC3917	39.5 (1.56)	37.5 (1.48)	17 (0.67)	15 (0.59)

* Capacitors (single item) can also be purchased.

Connection diagram

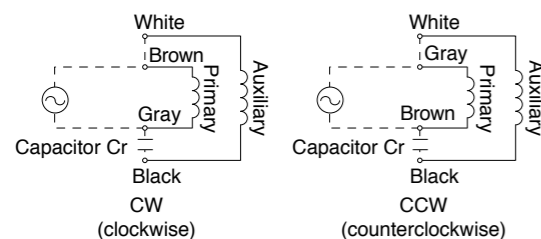

Speed-torque characteristics

M71X15G4L

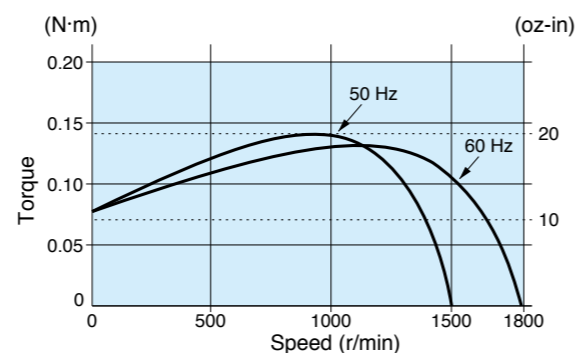

* Please read your User's manual carefully so that you will understand the operation and safety precautions before attempting to operate the system.

Features B-2 System configuration B-3 Coding system B-3 Model list B-4

Gear head (dimensions)

Scale: 1/3, Unit: mm (inch)

< □ is 25 or less >
MX7G□BA (ball bearing) Mass 0.38 kg(0.84 lb)
MX7G□MA (metal bearing) Mass 0.38 kg(0.84 lb)

< □ is 30 or more >
MX7G□B (ball bearing) Mass 0.45 kg(0.99 lb)
MX7G□M (metal bearing) Mass 0.45 kg(0.99 lb)

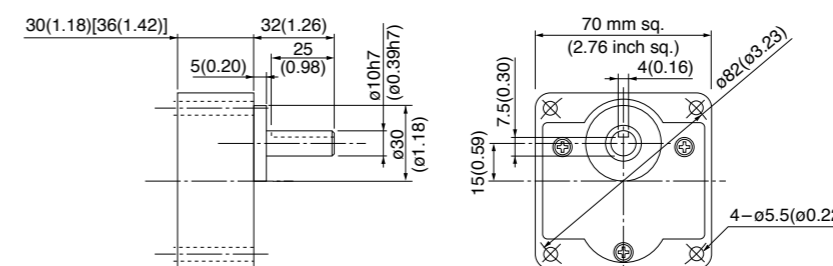

* Figures in [] represent the dimensions of MX7G□B (M) (1/30 or larger reduction ratio).

(Note) Because the dimensions may be subject to change, also check the determinate dimensions if the gear head is to be used for design.

Gear head combination B-58 Round shaft motor B-61 Decimal gear head B-448 Gear head -inch (U.S.A.) B-449 Controls C-4 Option D-2

Key and keyway (dimensions) [attachment]

MX7G□BA(B)
MX7G□MA(M)

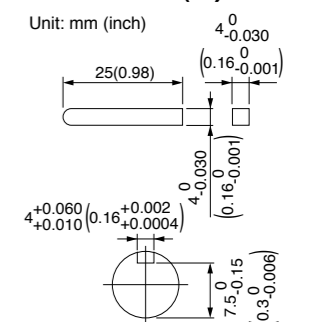

Specifications

Size	Motor model No.	Number of pole (P)	Output (W)	Voltage (V)	Frequency (Hz)	Rating (min)	Rating				Starting current (A)	Starting torque N-m (oz-in)	Capacitor (μF) (rated voltage)
							Input (W)	Current (A)	Speed (r/min)	Torque N-m (oz-in)			
80 mm sq.	M81X15G4L	4	15	100	50	Cont.	36	0.39	1225	0.12 (17.0)	0.62	0.10 (14.2)	4 (200 V)
							35	0.35	1550	0.09 (12.7)	0.60	0.10 (14.2)	
	M81X15G4Y	4	15	200	60	Cont.	36	0.19	1225	0.12 (17.0)	0.30	0.10 (14.2)	1 (400 V)
							35	0.18	1550	0.09 (12.7)	0.30	0.10 (14.2)	

* The specifications and wire connections of the round shaft motor are the same as those of the pinion shaft type. For the dimensional outline drawing, refer to page B-61.

Permissible torque at output shaft of gear head

* The speed shown below is a calculated value based on the synchronous rotational speed. Depending on the load, the speed is less than the indicated value by 2% to 20%.

Unit of permissible torque: upper (N·m) / lower (lb·in)

Reduction ratio	Speed (r/min)																							
	50 Hz	60 Hz	3	3.6	5	6	7.5	9	10	12.5	15	18	20	25	30	36	50	60	75	90	100	120	150	180
MX8G3B to MX8G180B (ball bearing)	0.24 (2.12)	0.28 (2.48)	0.39 (3.45)	0.47 (4.16)	0.59 (5.22)	0.71 (6.28)	0.80 (7.08)	0.98 (8.67)	1.18 (10.4)	1.37 (12.1)	1.57 (13.9)	1.86 (16.5)	2.25 (19.9)	2.74 (24.3)	3.82 (33.8)	4.61 (40.8)	5.49 (48.6)	6.57 (58.1)	7.35 (65.1)	7.84 (69.4)	7.84 (69.4)	7.84 (69.4)	7.84 (69.4)	7.84 (69.4)
MX8G3M to MX8G180M (metal bearing)	0.20 (1.77)	0.24 (2.12)	0.32 (2.83)	0.39 (3.45)	0.49 (4.34)	0.59 (5.22)	0.66 (5.84)	0.81 (7.17)	0.98 (8.67)	1.18 (10.4)	1.27 (11.2)	1.57 (13.9)	1.86 (16.5)	2.25 (19.9)	3.23 (28.6)	3.82 (33.8)	4.61 (40.8)	5.49 (48.6)	6.17 (54.6)	7.35 (65.1)	7.84 (69.4)	7.84 (69.4)	7.84 (69.4)	7.84 (69.4)
Rotational direction	Same as motor rotational direction											Reverse to motor rotational direction												

Permissible torque at output shaft of gear head using decimal gear head

* For external dimensions of the decimal gear head, refer to page B-448.

Applicable gear head	Reduction ratio	Speed (r/min)																						
		200	250	300	360	500	600	750	900	1000	1200	1500	1800											
MX8G□B (ball bearing)	MX8G10XB	Permissible torque	7.84 (69.4)	7.84 (69.4)	7.84 (69.4)	7.84 (69.4)	7.84 (69.4)	7.84 (69.4)	7.84 (69.4)	7.84 (69.4)	7.84 (69.4)	7.84 (69.4)	7.84 (69.4)	7.84 (69.4)	7.84 (69.4)	7.84 (69.4)	7.84 (69.4)	7.84 (69.4)	7.84 (69.4)	7.84 (69.4)	7.84 (69.4)	7.84 (69.4)	7.84 (69.4)	7.84 (69.4)
		Rotational direction	Same as motor rotational direction											Reverse to motor rotational direction										

Motor (dimensions)

M81X15G4L 4P 15 W 100 V
M81X15G4Y 4P 15 W 200 V

Scale: 1/3, Unit: mm (inch)

Mass 1.2 kg 2.65 lb
Helical gear
Module 0.5
Number of teeth 9

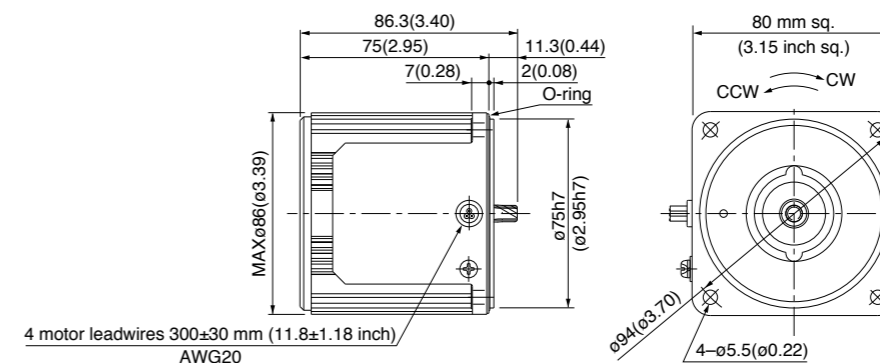

Capacitor (dimensions) [attachment]

Unit: mm (inch)

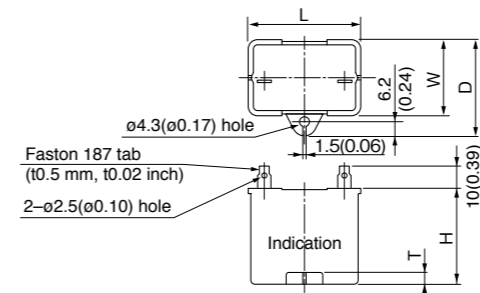

Capacitor cap (dimensions) [option]

Unit: mm (inch)

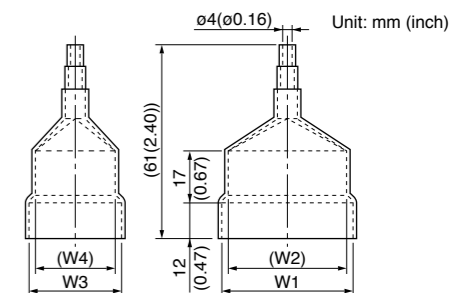

Capacitor dimension list

Unit: upper (mm) / lower (inch)

Model number of motor	Model number of capacitor (attachment)	L	W	D	H	T	Capacitor cap (option)	W1	W2	W3	W4
M81X15G4L	M0PC4M20	39.5 (1.56)	16 (0.63)	26.5 (1.04)	30.5 (1.20)	4 (0.16)	M0PC3917	39.5 (1.56)	37.5 (1.48)	17 (0.67)	15 (0.59)
M81X15G4Y	M0PC1M40	39.5 (1.56)	16.2 (0.64)	27 (1.06)	27 (1.06)	4 (0.16)	M0PC3917	39.5 (1.56)	37.5 (1.48)	17 (0.67)	15 (0.59)

* Capacitors (single item) can also be purchased.

Connection diagram

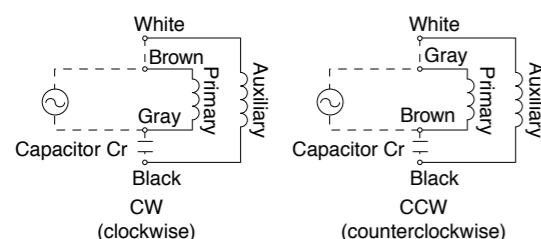

Speed-torque characteristics

M81X15G4L

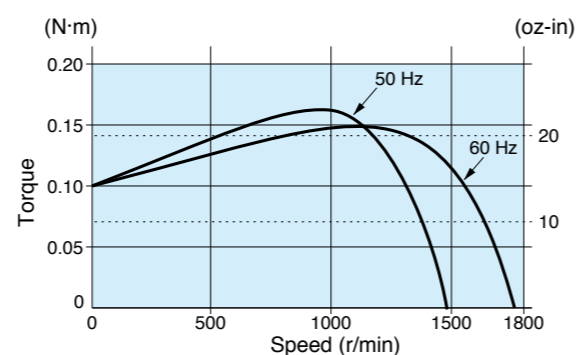

* Please read your User's manual carefully so that you will understand the operation and safety precautions before attempting to operate the system.

Features B-2 System configuration B-3 Coding system B-3 Model list B-4

Gear head (dimensions)

Scale: 1/3, Unit: mm (inch)

MX8G□B (ball bearing) Mass 0.6 kg (1.32 lb) MX8G□M (metal bearing) Mass 0.6 kg (1.32 lb)

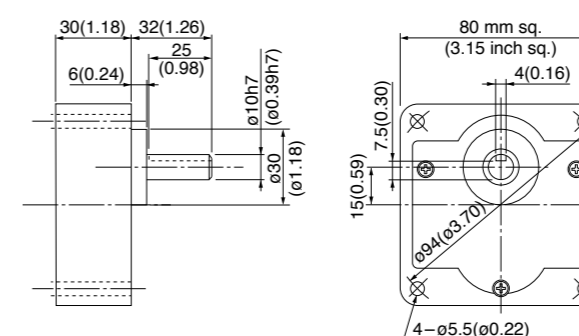

Key and keyway (dimensions) [attachment]

MX8G□B(M)

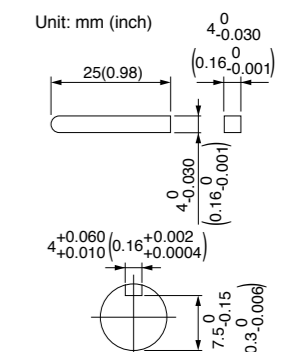

(Note) Because the dimensions may be subject to change, also check the determinate dimensions if the gear head is to be used for design.

Gear head combination B-59 Round shaft motor B-61 Decimal gear head B-448 Gear head -inch (U.S.A.) B-449 Controls C-4 Option D-2

Specifications

Size	Motor model No.	Number of pole (P)	Output (W)	Voltage (V)	Frequency (Hz)	Rating (min)	Rating				Starting current (A)	Starting torque N-m (oz-in)	Capacitor (μF) (rated voltage)
							Input (W)	Current (A)	Speed (r/min)	Torque N-m (oz-in)			
80 mm sq.	M81X25G4L	4	25	100	50	Cont.	51	0.55	1250	0.19 (26.9)	0.98	0.16 (22.7)	6 (200 V)
							49	0.48	1550	0.15 (21.2)	0.94	0.16 (22.7)	
	M81X25G4Y	4	25	200	50	Cont.	51	0.27	1250	0.19 (26.9)	0.50	0.16 (22.7)	1.5 (400 V)
							49	0.24	1575	0.15 (21.2)	0.47	0.16 (22.7)	

* The specifications and wire connections of the round shaft motor are the same as those of the pinion shaft type. For the dimensional outline drawing, refer to page B-61.

Permissible torque at output shaft of gear head

* The speed shown below is a calculated value based on the synchronous rotational speed. Depending on the load, the speed is less than the indicated value by 2% to 20%.

Unit of permissible torque: upper (N·m) / lower (lb·in)

Reduction ratio	Speed (r/min)	Unit of permissible torque: upper (N·m) / lower (lb·in)																							
		3	3.6	5	6	7.5	9	10	12.5	15	18	20	25	30	36	50	60	75	90	100	120	150	180		
50 Hz	50 Hz	0.39 (3.45)	0.47 (4.16)	0.66 (5.84)	0.78 (6.90)	0.98 (8.67)	1.18 (10.4)	1.27 (11.2)	1.57 (13.9)	1.96 (17.3)	2.35 (20.8)	2.55 (22.6)	3.14 (27.8)	3.82 (33.8)	4.61 (40.8)	6.37 (56.4)	7.64 (67.6)							7.84 (69.4)	
	60 Hz	600	500	360	300	240	200	180	144	120	100	90	72	60	50	36	30	24	20	18	15	12	10		
Applicable gear head	50 Hz	MX8G3B to MX8G180B (ball bearing)	0.39 (3.45)	0.47 (4.16)	0.66 (5.84)	0.78 (6.90)	0.98 (8.67)	1.18 (10.4)	1.27 (11.2)	1.57 (13.9)	1.96 (17.3)	2.35 (20.8)	2.55 (22.6)	3.14 (27.8)	3.82 (33.8)	4.61 (40.8)	6.37 (56.4)	7.64 (67.6)							7.84 (69.4)
		MX8G3M to MX8G180M (metal bearing)	0.32 (2.83)	0.39 (3.45)	0.55 (4.87)	0.66 (5.84)	0.81 (7.17)	0.98 (8.67)	1.08 (9.56)	1.27 (11.2)	1.57 (13.9)	1.96 (17.3)	2.06 (18.2)	2.65 (23.5)	3.14 (27.8)	3.82 (33.8)	5.29 (46.8)	6.37 (56.4)							7.84 (69.4)
Rotational direction		Same as motor rotational direction										Reverse to motor rotational direction													

Permissible torque at output shaft of gear head using decimal gear head

* For external dimensions of the decimal gear head, refer to page B-448.

Applicable gear head		Reduction ratio	Permissible torque													
Bearing	Decimal gear head		Speed (r/min)	200	250	300	360	500	600	750	900	1000	1200	1500	1800	
		MX8G□B (ball bearing) MX8G□M (metal bearing)		MX8G10XB	50 Hz	7.5	6	5	4.2	3	2.5	2	1.7	1.5	1.3	1
60 Hz	9		7.2		6	5	3.6	3	2.4	2	1.8	1.5	1.2	1		
Rotational direction		Same as motor rotational direction										Reverse to motor rotational direction				

Connection diagram

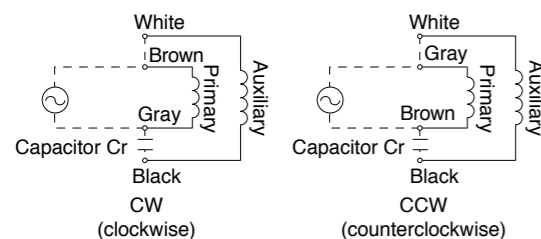

Speed-torque characteristics

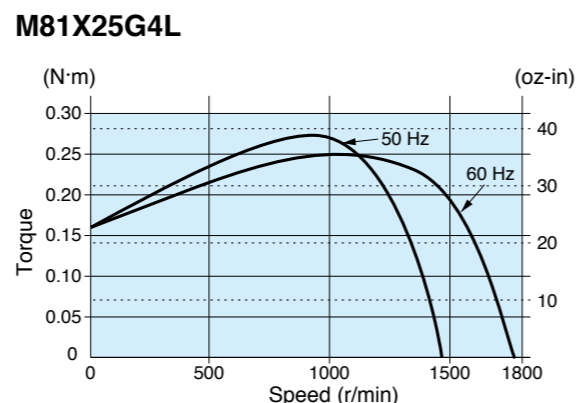

* Please read your User's manual carefully so that you will understand the operation and safety precautions before attempting to operate the system.

Features B-2 System configuration B-3 Coding system B-3 Model list B-4

Motor (dimensions)

Scale: 1/3, Unit: mm (inch)

M81X25G4L	4P 25 W 100 V
M81X25G4Y	4P 25 W 200 V

Mass	Helical gear	Module	Number of teeth
1.5 kg 3.31 lb		0.5	9

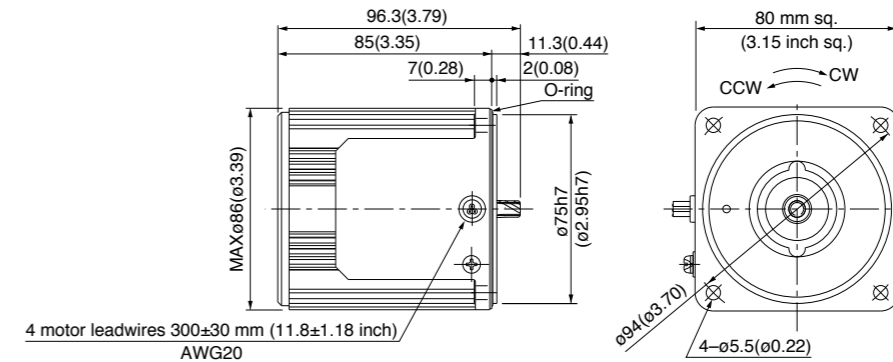

Capacitor (dimensions) [attachment]

Unit: mm (inch)

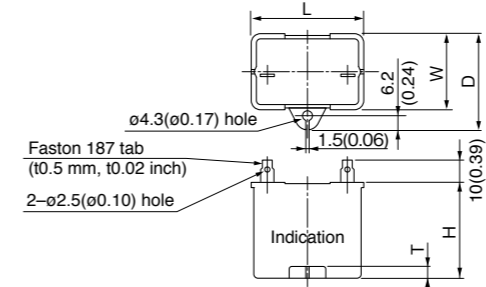

Capacitor cap (dimensions) [option]

Unit: mm (inch)

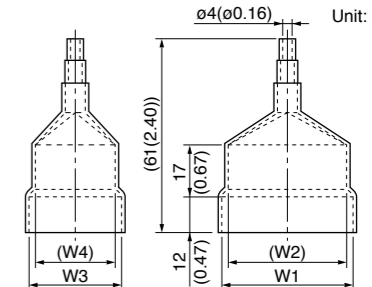

Capacitor dimension list

Unit: upper (mm) / lower (inch)

Model number of motor	Model number of capacitor (attachment)	L	W	D	H	T	Capacitor cap (option)	W1	W2	W3	W4
M81X25G4L	M0PC6M20	39.5 (1.56)	17.5 (0.69)	28 (1.10)	30.5 (1.20)	4 (0.16)	M0PC3917	39.5 (1.56)	37.5 (1.48)	17 (0.67)	15 (0.59)
M81X25G4Y	M0PC1.5M40	39.5 (1.56)	22 (0.87)	32.5 (1.28)	32.5 (1.28)	4 (0.16)	M0PC3922	39.5 (1.56)	37.5 (1.48)	22 (0.87)	20 (0.79)

* Capacitors (single item) can also be purchased.

Gear head (dimensions)

Scale: 1/3, Unit: mm (inch)

MX8G□B (ball bearing) Mass 0.6 kg(1.32 lb)	MX8G□M (metal bearing) Mass 0.6 kg(1.32 lb)
--	---

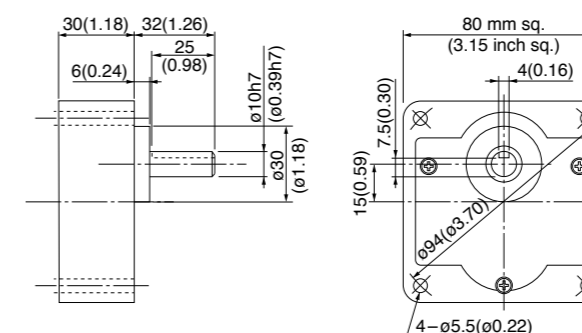

Key and keyway (dimensions) [attachment]

MX8G□B(M)

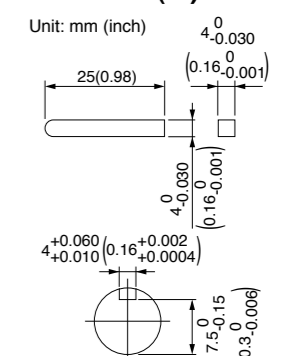

(Note) Because the dimensions may be subject to change, also check the determinate dimensions if the gear head is to be used for design.

Gear head combination B-59 Round shaft motor B-61 Decimal gear head B-448 Gear head -inch (U.S.A.) B-449 Controls C-4 Option D-2

Specifications

Size	Motor model No.	Number of pole (P)	Output (W)	Voltage (V)	Frequency (Hz)	Rating (min)	Rating				Starting current (A)	Starting torque N-m (oz-in)	Capacitor (μF) (rated voltage)
							Input (W)	Current (A)	Speed (r/min)	Torque N-m (oz-in)			
90 mm sq.	M91X40G4L	4	40	100	50	Cont.	78	0.86	1225	0.30 (42.5)	1.5	0.24 (34.0)	10 (200 V)
							72	0.72	1550	0.25 (35.4)	1.5	0.25 (35.4)	
	M91X40G4Y	4	40	200	60	Cont.	79	0.43	1250	0.30 (42.5)	0.83	0.25 (35.4)	2.5 (400 V)
							72	0.36	1575	0.24 (34.0)	0.76	0.25 (35.4)	

* The specifications and wire connections of the round shaft motor are the same as those of the pinion shaft type. For the dimensional outline drawing, refer to page B-61.

Permissible torque at output shaft of gear head

* The speed shown below is a calculated value based on the synchronous rotational speed. Depending on the load, the speed is less than the indicated value by 2% to 20%.

Unit of permissible torque: upper (N·m) / lower (lb-in)

Reduction ratio	Unit of permissible torque: upper (N·m) / lower (lb-in)																							
	3	3.6	5	6	7.5	9	10	12.5	15	18	20	25	30	36	50	60	75	90	100	120	150	180		
Speed (r/min)	50 Hz	500	416.7	300	250	200	166.7	150	120	100	83.3	75	60	50	41.7	30	25	20	16.7	15	12.5	10	8.3	
	60 Hz	600	500	360	300	240	200	180	144	120	100	90	72	60	50	36	30	24	20	18	15	12	10	
Applicable gear head	MX9G3B to MX9G180B (ball bearing)	50 Hz	0.66 (5.84)	0.78 (6.90)	1.08 (9.56)	1.27 (11.2)	1.57 (13.9)	1.86 (16.5)	2.25 (19.9)	2.74 (24.3)	3.23 (28.6)	3.92 (34.7)	4.41 (39.0)	5.29 (46.8)	6.37 (56.4)	7.94 (70.3)	9.80 (86.7)							9.80 (86.7)
		60 Hz	0.55 (4.87)	0.66 (5.84)	0.90 (7.97)	1.08 (9.56)	1.27 (11.2)	1.57 (13.9)	1.76 (15.6)	2.25 (19.9)	2.74 (24.3)	3.23 (28.6)	3.53 (31.2)	4.41 (39.0)	5.29 (46.8)	6.37 (56.4)	8.82 (78.1)							9.80 (86.7)
Rotational direction		Same as motor rotational direction											Reverse to motor rotational direction											

Permissible torque at output shaft of gear head using decimal gear head

* For external dimensions of the decimal gear head, refer to page B-448.

Applicable gear head		Reduction ratio		200	250	300	360	500	600	750	900	1000	1200	1500	1800
Bearing	Decimal gear head	Speed (r/min)	50 Hz	50 Hz	6	5	4.2	3	2.5	2	1.7	1.5	1.3	1	0.8
			60 Hz	9	7.2	6	5	3.6	3	2.4	2	1.8	1.5	1.2	1
MX9G□B (ball bearing) MX9G□M (metal bearing)	MX9G10XB	Permissible torque	N-m (lb-in)	9.80 (86.7)	9.80 (86.7)	9.80 (86.7)	9.80 (86.7)	9.80 (86.7)	9.80 (86.7)	9.80 (86.7)	9.80 (86.7)	9.80 (86.7)	9.80 (86.7)	9.80 (86.7)	9.80 (86.7)
		Rotational direction		Same as motor rotational direction			Reverse to motor rotational direction								

Connection diagram

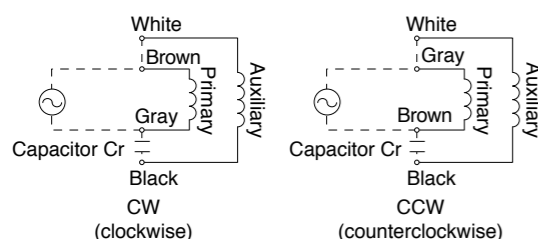

Speed-torque characteristics

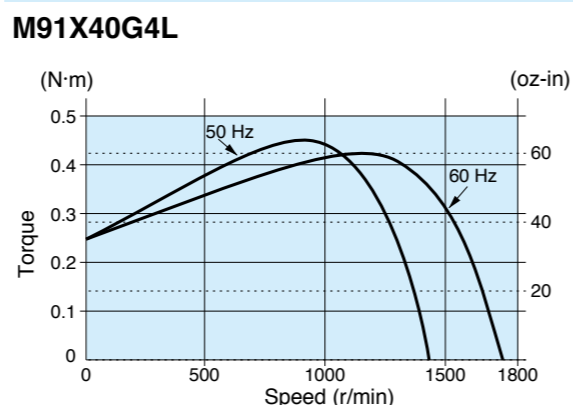

* Please read your User's manual carefully so that you will understand the operation and safety precautions before attempting to operate the system.

Features B-2 System configuration B-3 Coding system B-3 Model list B-4

Motor (dimensions)

M91X40G4L	4P 40 W 100 V
M91X40G4Y	4P 40 W 200 V

Scale: 1/3, Unit: mm (inch)

Mass	Helical gear	Module	Number of teeth
2.4 kg 5.29 lb		0.55	9

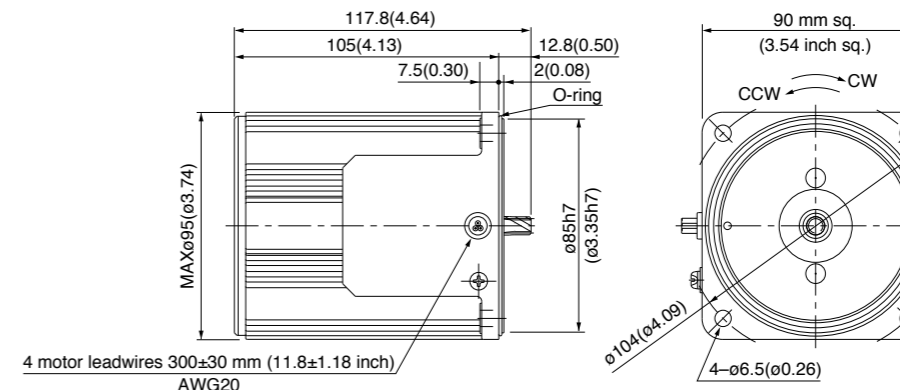

Capacitor (dimensions) [attachment]

Unit: mm (inch)

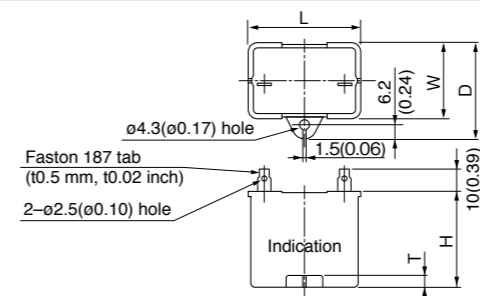

Capacitor cap (dimensions) [option]

Unit: mm (inch)

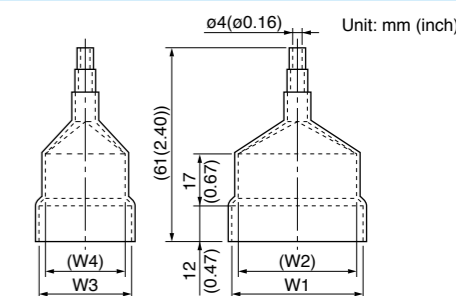

Capacitor dimension list

Unit: upper (mm) / lower (inch)

Model number of motor	Model number of capacitor (attachment)	L	W	D	H	T	Capacitor cap (option)	W1	W2	W3	W4
M91X40G4L	M0PC10M20	39.5 (1.56)	26.7 (1.05)	37 (1.46)	32 (1.26)	4 (0.16)	M0PC3926	39.5 (1.56)	37.5 (1.48)	26 (1.02)	25 (0.98)
M91X40G4Y	M0PC2.5M40	49.7 (1.96)	24 (0.94)	34.5 (1.36)	34.5 (1.36)	4 (0.16)	M0PC5026	50 (1.97)	48 (1.89)	26 (1.02)	22 (0.87)

* Capacitors (single item) can also be purchased.

Gear head (dimensions)

Scale: 1/3, Unit: mm (inch)

MX9G□B (ball bearing)	Mass 0.8 kg (1.76 lb)	MX9G□M (metal bearing)	Mass 0.8 kg (1.76 lb)
-----------------------	-----------------------	------------------------	-----------------------

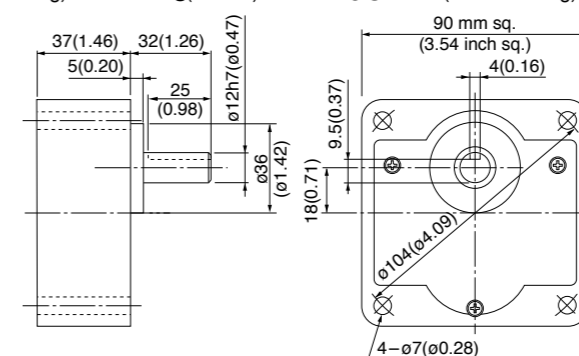

Key and keyway (dimensions) [attachment]

Unit: mm (inch)

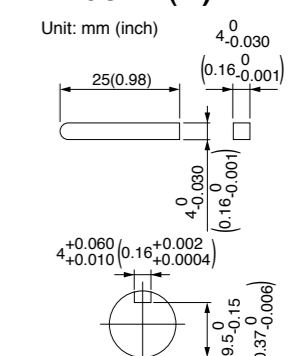

(Note) Because the dimensions may be subject to change, also check the determinate dimensions if the gear head is to be used for design.

Gear head combination B-59 Round shaft motor B-61 Decimal gear head B-448 Gear head -inch (U.S.A.) B-449 Controls C-4 Option D-2

Induction motor (leadwire)

UL US CE CCC 90 mm (3.54 inch) sq. 40 W

Specifications

Size	Motor model No.	Number of pole (P)	Output (W)	Voltage (V)	Frequency (Hz)	Rating (min)	Rating			Starting current (A)	Starting torque N-m (oz-in)	Capacitor (μ F) (rated voltage)	
							Input (W)	Current (A)	Speed (r/min)				
90 mm sq.	M91X40G4LG	4	40	100	50	Cont.	76	0.83	1250	0.31 (43.9)	1.7	0.26 (36.8)	
	M91X40G4LGA						70	0.70	1600	0.24 (34.0)	1.5	0.26 (36.8)	
	M91X40G4DG	4	40	110	60	Cont.	72	0.67	1625	0.24 (34.0)	1.7	0.26 (36.8)	
	M91X40G4DGA						74	0.68	1625	0.24 (34.0)	1.8	0.27 (38.2)	
	M91X40G4YG	4	40	200	50	Cont.	77	0.39	1175	0.33 (46.7)	0.64	0.26 (36.8)	
	M91X40G4YGA						77	0.39	1525	0.25 (35.4)	0.62	0.26 (36.8)	
	M91X40G4GG	M91X40G4GGA	4	40	220	50	Cont.	78	0.37	1250	0.31 (43.9)	0.69	0.26 (36.8)
								74	0.34	1575	0.24 (34.0)	0.65	0.26 (36.8)
230			50	Cont.	79	0.37	1275	0.30 (42.5)	0.72	0.28 (39.6)			
					77	0.33	1600	0.24 (34.0)	0.68	0.28 (39.6)			

The specifications and wire connections of the round shaft motor are the same as those of the pinion shaft type. For the dimensional outline drawing, refer to page B-61.
 The models with a motor model number to which "A" is suffixed are not equipped with a capacitor cap.
 The models with a motor model number to which "A" is suffixed are not sold or available in Japan.

Permissible torque at output shaft of gear head

* The speed shown below is a calculated value based on the synchronous rotational speed. Depending on the load, the speed is less than the indicated value by 2 % to 20 %.

Unit of permissible torque: upper (N-m) / lower (lb-in)

Reduction ratio	3	3.6	5	6	7.5	9	10	12.5	15	18	20	25	30	36	50	60	75	90	100	120	150	180		
Speed (r/min)	50 Hz	500	416.7	300	250	200	166.7	150	120	100	83.3	75	60	50	41.7	30	25	20	16.7	15	12.5	10	8.3	
Applicable gear head	60 Hz	600	500	360	300	240	200	180	144	120	100	90	72	60	50	36	30	24	20	18	15	12	10	
	MX9G3B to MX9G180B (ball bearing)	50 Hz	0.66 (5.84)	0.78 (6.90)	1.08 (9.56)	1.27 (11.2)	1.57 (13.9)	1.86 (16.5)	2.25 (19.9)	2.74 (24.3)	3.23 (28.6)	3.92 (34.7)	4.41 (39.0)	5.29 (46.8)	6.37 (56.4)	7.94 (70.3)	9.80 (86.7)							
MX9G3M to MX9G180M (metal bearing)	60 Hz	0.55 (4.87)	0.66 (5.84)	0.90 (7.97)	1.08 (9.56)	1.27 (11.2)	1.57 (13.9)	1.76 (15.6)	2.25 (19.9)	2.74 (24.3)	3.23 (28.6)	3.53 (31.2)	4.41 (39.0)	5.29 (46.8)	6.37 (56.4)	8.82 (78.1)								
Rotational direction	Same as motor rotational direction											Reverse to motor rotational direction												

Permissible torque at output shaft of gear head using decimal gear head

* For external dimensions of the decimal gear head, refer to page B-448.

Applicable gear head		Reduction ratio	200 250 300 360 500 600 750 900 1000 1200 1500 1800													
Bearing	Decimal gear head		Speed (r/min)	50 Hz	7.5	6	5	4.2	3	2.5	2	1.7	1.5	1.3	1	0.8
MX9G□B (ball bearing)	MX9G10XB	Permissible torque	N-m (lb-in)	9.80 (86.7)	9.80 (86.7)	9.80 (86.7)	9.80 (86.7)	9.80 (86.7)	9.80 (86.7)	9.80 (86.7)	9.80 (86.7)	9.80 (86.7)	9.80 (86.7)	9.80 (86.7)	9.80 (86.7)	9.80 (86.7)
		Rotational direction	Same as motor rotational direction	Reverse to motor rotational direction												

Connection diagram

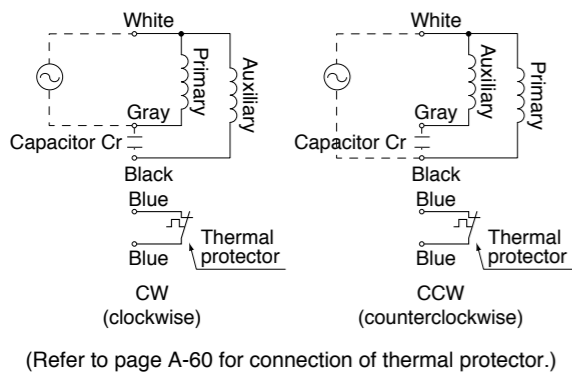

Speed-torque characteristics

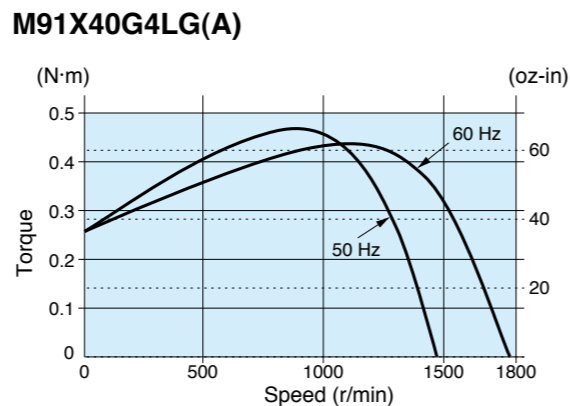

* Please read your User's manual carefully so that you will understand the operation and safety precautions before attempting to operate the system.

Features B-2 System configuration B-3 Coding system B-3 Model list B-4

Motor (dimensions)

Scale: 1/3, Unit: mm (inch)

M91X40G4LG(A) 4P 40 W 100 V
 M91X40G4DG(A) 4P 40 W 110 V / 115 V
 M91X40G4YG(A) 4P 40 W 200 V
 M91X40G4GG(A) 4P 40 W 220 V / 230 V

Mass 2.4 kg 5.29 lb
 Helical gear
 Module 0.55
 Number of teeth 9

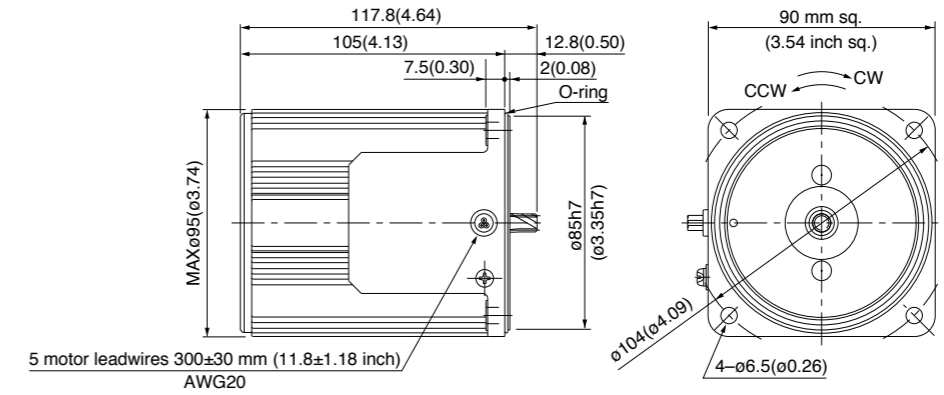

Capacitor (dimensions) [attachment]

Unit: mm (inch)

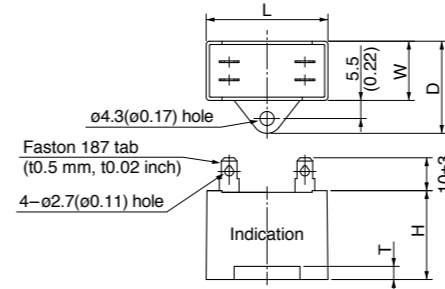

Capacitor cap (dimensions) [attachment]

Unit: mm (inch)

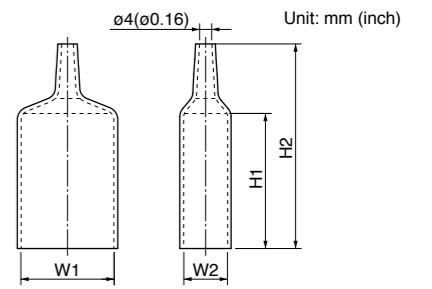

Capacitor dimension list

Model number of motor	Model number of capacitor (attachment)	L	W	D	H	T	Capacitor cap (attachment)	W1	W2	H1	H2
M91X40G4LG(A)	M0PC12M25G	58 (2.28)	22 (0.87)	32 (1.26)	35 (1.38)	4 (0.16)	M0PC5822G	58 (2.28)	22 (0.87)	55 (2.17)	78 (3.07)
M91X40G4DG(A)	M0PC10M25G	58 (2.28)	21 (0.83)	31 (1.22)	31 (1.22)	4 (0.16)	M0PC5821G	58 (2.28)	21 (0.83)	55 (2.17)	78 (3.07)
M91X40G4YG(A)	M0PC3M45G	58 (2.28)	21 (0.83)	31 (1.22)	31 (1.22)	4 (0.16)	M0PC5821G	58 (2.28)	21 (0.83)	55 (2.17)	78 (3.07)
M91X40G4GG(A)	M0PC2.5M45G	48 (1.89)	21 (0.83)	31 (1.22)	31 (1.22)	4 (0.16)	M0PC4821G	48 (1.89)	21 (0.83)	55 (2.17)	78 (3.07)

* The models with a motor model number to which "A" is suffixed are not equipped with a capacitor cap.
 * Capacitors (single item), capacitors cap (single item) can also be purchased.

Gear head (dimensions)

Scale: 1/3, Unit: mm (inch)

MX9G□B (ball bearing) Mass 0.8 kg (1.76 lb) MX9G□M (metal bearing) Mass 0.8 kg (1.76 lb)

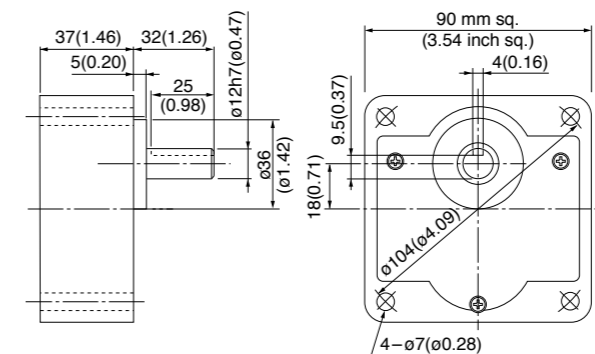

Key and keyway (dimensions) [attachment]

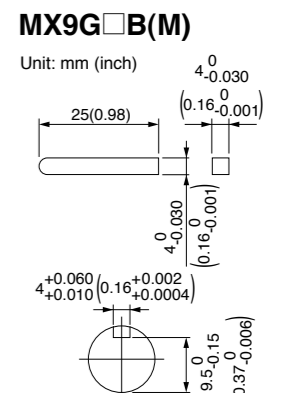

(Note) Because the dimensions may be subject to change, also check the determinate dimensions if the gear head is to be used for design.

Gear head combination B-59 Round shaft motor B-61 Decimal gear head B-448 Gear head -inch (U.S.A.) B-449 Controls C-4 Option D-2

Induction motor (leadwire)

90 mm (3.54 inch) sq. 60 W

• Specifications

Size	Motor model No.	Number of pole (P)	Output (W)	Voltage (V)	Frequency (Hz)	Rating (min)	Rating				Starting current (A)	Starting torque N-m (oz-in)	Capacitor (μF) (rated voltage)
							Input (W)	Current (A)	Speed (r/min)	Torque N-m (oz-in)			
90 mm sq.	M91Z60G4L	4	60	100	50	Cont.	118	1.3	1250	0.46 (65.1)	2.2	0.41 (58.1)	15 (210 V)
							117	1.2	1550	0.36 (51.0)	2.2	0.42 (59.5)	
	M91Z60G4Y	4	60	200	50	Cont.	120	0.65	1250	0.46 (65.1)	1.1	0.42 (59.5)	3.8 (400 V)
							119	0.59	1550	0.36 (51.0)	1.1	0.44 (62.3)	

* The specifications and wire connections of the round shaft motor are the same as those of the pinion shaft type. For the dimensional outline drawing, refer to page B-62.

• Permissible torque at output shaft of gear head

* The speed shown below is a calculated value based on the synchronous rotational speed. Depending on the load, the speed is less than the indicated value by 2% to 20%.

Unit of permissible torque: upper (N·m) / lower (lb·in)

Reduction ratio	Unit of permissible torque: upper (N·m) / lower (lb·in)																									
	3	3.6	5	6	7.5	9	10	12.5	15	18	20	25	30	36	50	60	75	90	100	120	150	180	200			
Speed (r/min)	50 Hz		500	416.7	300	250	200	166.7	150	120	100	83.3	75	60	50	41.7	30	25	20	16.7	15	12.5	10	8.3	7.5	
	60 Hz		600	500	360	300	240	200	180	144	120	100	90	72	60	50	36	30	24	20	18	15	12	10	9	
Applicable gear head	MZ9G3B to MZ9G200B (ball bearing / hinge not attached) MY9G3B to MY9G200B (ball bearing / hinge attached)	50 Hz	0.98 (8.7)	1.18 (10.4)	1.57 (13.9)	1.96 (17.3)	2.35 (20.8)	2.94 (26.0)	3.14 (27.8)	3.92 (34.7)	4.70 (41.6)	5.59 (49.5)	6.27 (55.5)	7.55 (66.8)	9.11 (80.6)	11.0 (97.4)	15.2 (135)	17.8 (158)							19.6 (173)	
		60 Hz	0.78 (6.9)	0.98 (8.7)	1.37 (12.1)	1.57 (13.9)	1.96 (17.3)	2.65 (23.5)	3.33 (29.5)	3.92 (34.7)	4.70 (41.6)	5.29 (46.8)	6.47 (57.3)	7.55 (66.8)	9.11 (80.6)	11.2 (112)	12.6 (135)	15.2 (135)							19.6 (173)	
Rotational direction		Same as motor rotational direction					Reverse to motor rotational direction					Same as motor rotational direction														

• Permissible torque at output shaft of gear head using decimal gear head

* For external dimensions of the decimal gear head, refer to page B-448.

Applicable gear head		Reduction ratio	250	300	360	500	600	750	900	1000	1200	1500	1800
Bearing	Decimal gear head	50 Hz	6	5	4.2	3	2.5	2	1.7	1.5	1.3	1	0.8
		60 Hz	7.2	6	5	3.6	3	2.4	2	1.8	1.5	1.2	1
MZ9G□B (ball bearing / Hinge not attached) MY9G□B (ball bearing / Hinge attached)	MZ9G10XB	Permissible torque	N-m (lb-in)	19.6 (173)	19.6 (173)	19.6 (173)	19.6 (173)	19.6 (173)	19.6 (173)	19.6 (173)	19.6 (173)	19.6 (173)	19.6 (173)
		Rotational direction	Reverse to motor rotational direction	Same as motor rotational direction									

Motor (dimensions)

Scale: 1/4, Unit: mm (inch)

M91Z60G4L 4P 60 W 100 V (with fan)
M91Z60G4Y 4P 60 W 200 V (with fan)

Mass 2.7 kg 5.95 lb
Helical gear
Module 0.6
Number of teeth 9

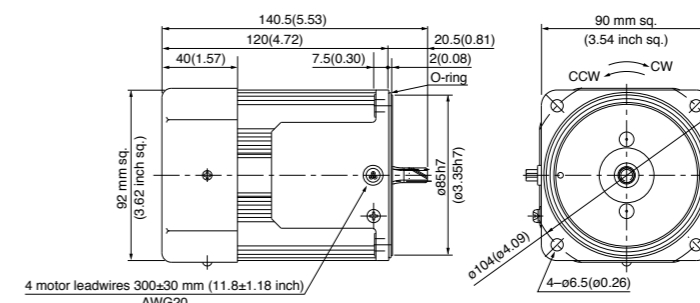

Capacitor (dimensions) [attachment]

Unit: mm (inch)

Capacitor cap (dimensions) [option]

Unit: mm (inch)

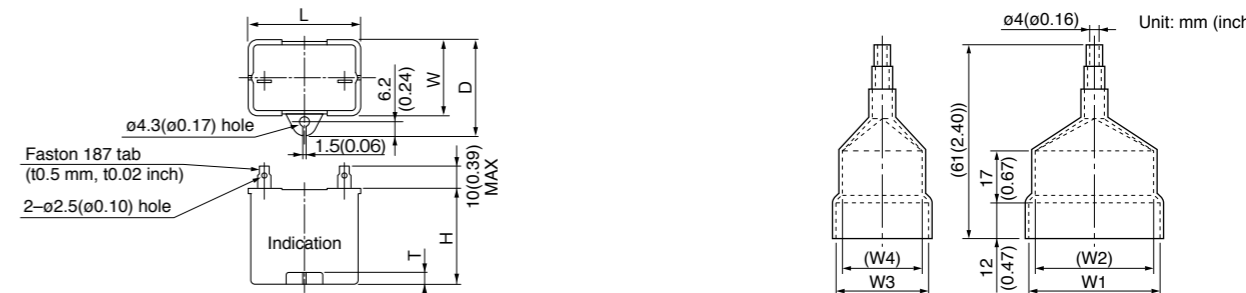

• Capacitor dimension list Unit: upper (mm) / lower (inch)

Model number of motor	Model number of capacitor (attachment)	L	W	D	H	T	Capacitor cap (option)	W1	W2	W3	W4
M91Z60G4L	M0PC15M20	39.5 (1.56)	26.7 (1.05)	37 (1.46)	4.1 (1.61)	4 (0.16)	M0PC3926	39.5 (1.56)	37.5 (1.48)	26 (1.02)	25 (0.98)
M91Z60G4Y	M0PC3.8M40	50 (1.97)	26.7 (1.05)	37.5 (1.48)	38 (1.50)	4 (0.16)	M0PC5026	50 (1.97)	48 (1.89)	26 (1.02)	22 (0.87)

* Capacitors (single item) can also be purchased.

Connection diagram

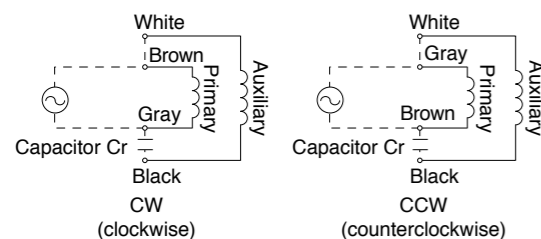

Speed-torque characteristics

M91Z60G4L

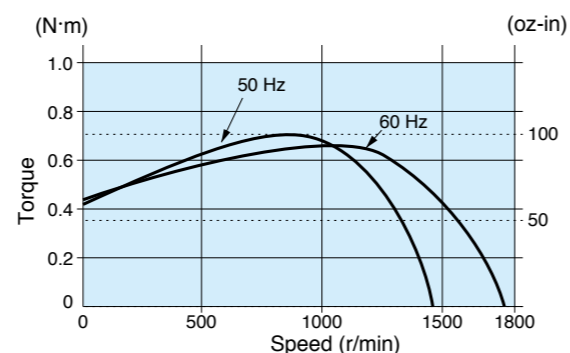

* Please read your User's manual carefully so that you will understand the operation and safety precautions before attempting to operate the system.

Features B-2 System configuration B-3 Coding system B-3 Model list B-4

Gear head (dimensions)

Scale: 1/4, Unit: mm (inch)

MZ9G□B (ball bearing / hinge not attached) Mass 1.4 kg (3.09 lb)
MY9G□B (ball bearing / hinge attached) Mass 1.4 kg (3.09 lb)

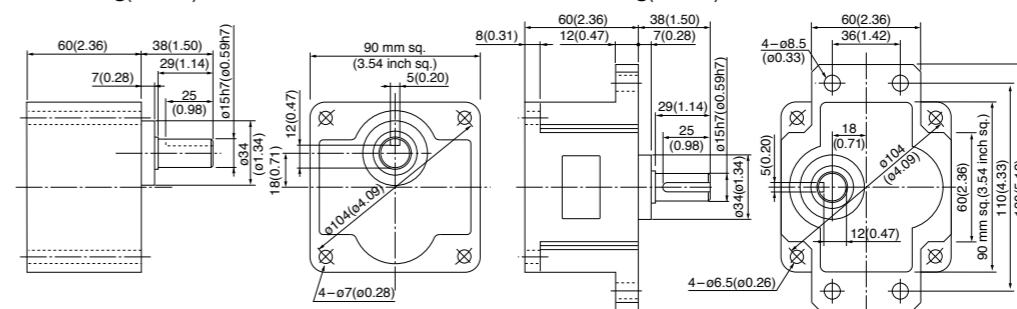

Note) MZ / MY is available for a gear head of either type.

(Note) Because the dimensions may be subject to change, also check the determinate dimensions if the gear head is to be used for design.

Gear head combination B-59 Round shaft motor B-62 Decimal gear head B-448 Gear head -inch (U.S.A.) B-449 Controls C-4 Option D-2

Key and keyway (dimensions) [attachment]

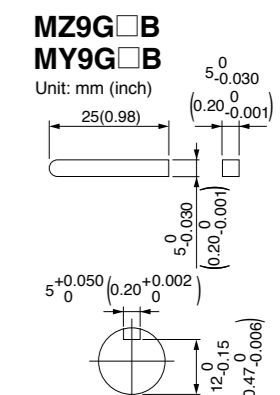

Specifications

Size	Motor model No.	Number of pole (P)	Output (W)	Voltage (V)	Frequency (Hz)	Rating (min)	Rating			Starting current (A)	Starting torque N-m (oz-in)	Capacitor (μF) (rated voltage)
							Input (W)	Current (A)	Speed (r/min)			
90 mm sq.	M91Z60G4LG M91Z60G4LGA	4	60	100	50	Cont.	119	1.3	1250	0.46 (65.1)	2.4	0.44 (62.3)
					60		112	1.2	1575	0.36 (51.0)	2.3	0.44 (62.3)
	M91Z60G4DG M91Z60G4DGA	4	60	110	60	Cont.	120	1.1	1625	0.35 (49.6)	2.5	0.49 (69.4)
					60		127	1.2	1625	0.35 (49.6)	2.6	0.53 (75.1)
	M91Z60G4YG M91Z60G4YGA	4	60	200	50	Cont.	114	0.57	1225	0.47 (66.6)	1.0	0.44 (62.3)
					60		122	0.62	1550	0.37 (52.4)	1.0	0.44 (62.3)
	M91Z60G4GG M91Z60G4GGA	4	60	220	50	Cont.	121	0.58	1275	0.45 (63.7)	1.1	0.49 (69.4)
					60		120	0.55	1600	0.36 (51.0)	1.1	0.49 (69.4)
	M91Z60G4GG M91Z60G4GGA	4	60	230	50	Cont.	129	0.61	1300	0.44 (62.3)	1.1	0.53 (75.0)
					60		126	0.55	1625	0.35 (49.6)	1.1	0.53 (75.1)
	M91Z60G4GGB M91Z60G4GGC	4	60	220	50	Cont.	106	0.48	1350	0.42 (4.3)	1.0	0.40 (4.0)
					60		123	0.59	1650	0.34 (3.5)	0.97	0.40 (4.0)
M91Z60G4GGB M91Z60G4GGC	4	60	230	50	Cont.	112	0.49	1375	0.42 (4.3)	1.1	0.43 (4.4)	
				60		128	0.59	1675	0.34 (3.5)	1.0	0.43 (4.4)	

The specifications and wire connections of the round shaft motor are the same as those of the pinion shaft type. For the dimensional outline drawing, refer to page B-62.
 The models with a motor model number to which "A" is suffixed are not equipped with a capacitor cap.
 The models with a motor model number to which "A" is suffixed are not sold or available in Japan.

Permissible torque at output shaft of gear head

* The speed shown below is a calculated value based on the synchronous rotational speed. Depending on the load, the speed is less than the indicated value by 2% to 20%.

Unit of permissible torque: upper (N·m) / lower (lb-in)

Reduction ratio	3	3.6	5	6	7.5	9	10	12.5	15	18	20	25	30	36	50	60	75	90	100	120	150	180	200	
Speed (r/min)	50 Hz	500	416.7	300	250	200	166.7	150	120	100	83.3	75	60	50	41.7	30	25	20	16.7	15	12.5	10	8.3	7.5
Applicable gear head	50 Hz	0.98 (8.7)	1.18 (10.4)	1.57 (13.9)	1.96 (17.3)	2.35 (20.8)	2.94 (26.0)	3.14 (27.8)	3.92 (34.7)	4.70 (41.6)	5.59 (49.5)	6.27 (55.5)	7.55 (66.8)	9.11 (80.6)	11.0 (97.4)	15.2 (135)	17.8 (158)							
	60 Hz	0.78 (6.9)	0.98 (8.7)	1.37 (12.1)	1.57 (13.9)	1.96 (17.3)	2.65 (23.5)	3.33 (29.5)	3.92 (34.7)	4.70 (41.6)	5.29 (46.8)	6.47 (57.3)	7.55 (66.8)	9.11 (80.6)	12.6 (112)	15.2 (135)								
Rotational direction	Same as motor rotational direction							Reverse to motor rotational direction							Same as motor rotational direction									

Permissible torque at output shaft of gear head using decimal gear head

* For external dimensions of the decimal gear head, refer to page B-448.

Applicable gear head		Reduction ratio	250	300	360	500	600	750	900	1000	1200	1500	1800
Bearing	Decimal gear head	Speed (r/min)	50 Hz	6	5	4.2	3	2.5	2	1.7	1.5	1.3	1
		60 Hz	7.2	6	5	3.6	3	2.4	2	1.8	1.5	1.2	1
MZ9G□B (ball bearing / hinge not attached) MY9G□B (ball bearing / hinge attached)	MZ9G10XB	Permissible torque	N·m	19.6	19.6	19.6	19.6	19.6	19.6	19.6	19.6	19.6	19.6
		(lb-in)	(173)	(173)	(173)	(173)	(173)	(173)	(173)	(173)	(173)	(173)	(173)
Rotational direction		Reverse to motor rotational direction				Same as motor rotational direction							

Connection diagram

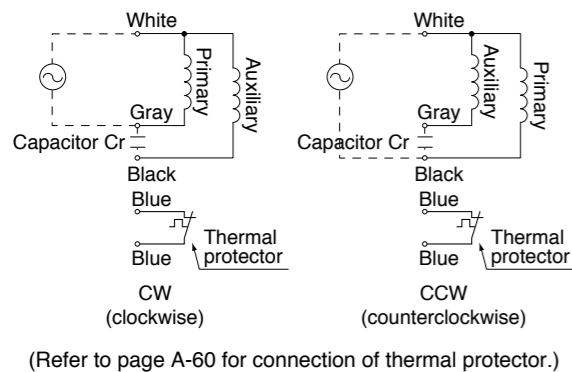

Speed-torque characteristics

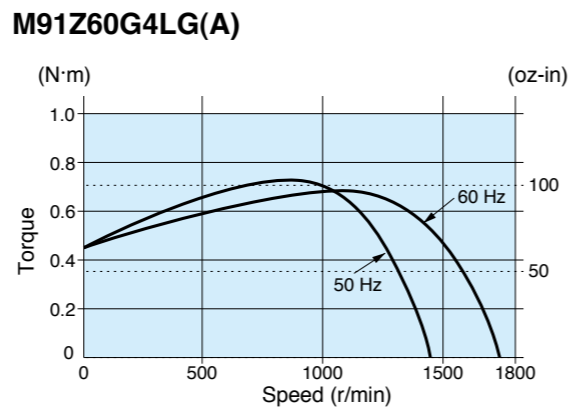

* Please read your User's manual carefully so that you will understand the operation and safety precautions before attempting to operate the system.

Features B-2 System configuration B-3 Coding system B-3 Model list B-4

Motor (dimensions)

Scale: 1/4, Unit: mm (inch)

M91Z60G4LG(A)	4P 60 W 100 V (with fan)
M91Z60G4DG(A)	4P 60 W 110 V / 115 V (with fan)
M91Z60G4YG(A)	4P 60 W 200 V (with fan)
M91Z60G4GG(A)	4P 60 W 220 V / 230 V (with fan)
M91Z60G4GGB	4P 60 W 220 V / 230 V (with fan)
M91Z60G4GGC	4P 60 W 220 V / 230 V (with fan)

Mass	2.7 kg 5.95 lb
Helical gear	
Module	0.6
Number of teeth	9

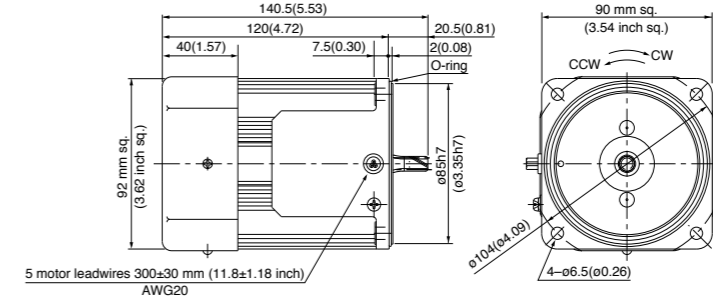

Capacitor (dimensions) [attachment]

Unit: mm (inch)

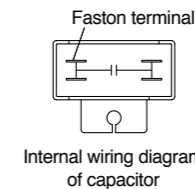
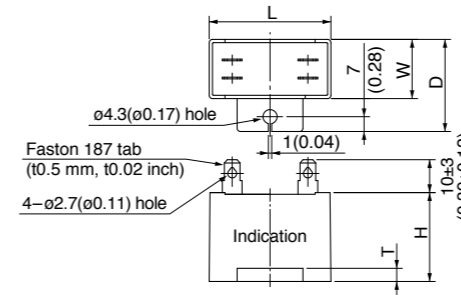

Capacitor cap (dimensions) [attachment]

Unit: mm (inch)

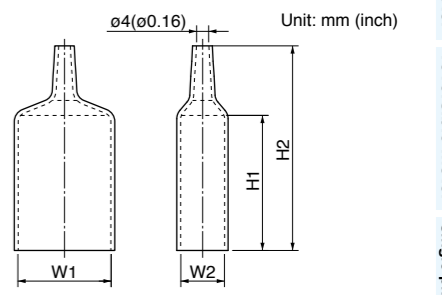

Capacitor dimension list Unit: upper (mm) / lower (inch)

Model number of motor	Model number of capacitor (attachment)	L	W	D	H	T	Capacitor cap (attachment)	W1	W2	H1	H2
M91Z60G4LG(A)	M0PC20M25G	58 (2.28)	29 (1.14)	44 (1.73)	41 (1.61)	4 (0.16)	M0PC5829G	58 (2.28)	29 (1.14)	55 (2.17)	78 (3.07)
M91Z60G4DG(A)	M0PC18M25G	58 (2.28)	29 (1.14)	44 (1.73)	41 (1.61)	4 (0.16)	M0PC5829G	58 (2.28)	29 (1.14)	55 (2.17)	78 (3.07)
M91Z60G4YG(A)	M0PC5M45G	58 (2.28)	29 (1.14)	44 (1.73)	41 (1.61)	4 (0.16)	M0PC5829G	58 (2.28)	29 (1.14)	55 (2.17)	78 (3.07)
M91Z60G4GG(A)	M0PC4.5M45G	58 (2.28)	23.5 (0.93)	38.5 (1.52)	37 (1.46)	4 (0.16)	M0PC5823G	58 (2.28)	23.5 (0.93)	55 (2.17)	78 (3.07)
M91Z60G4GGB											
M91Z60G4GGC											

* The models with a motor model number to which "A" or "B" is suffixed are not equipped with a capacitor cap.
 * Capacitors (single item), capacitors cap (single item) can also be purchased.

Gear head (dimensions)

Scale: 1/4, Unit: mm (inch)

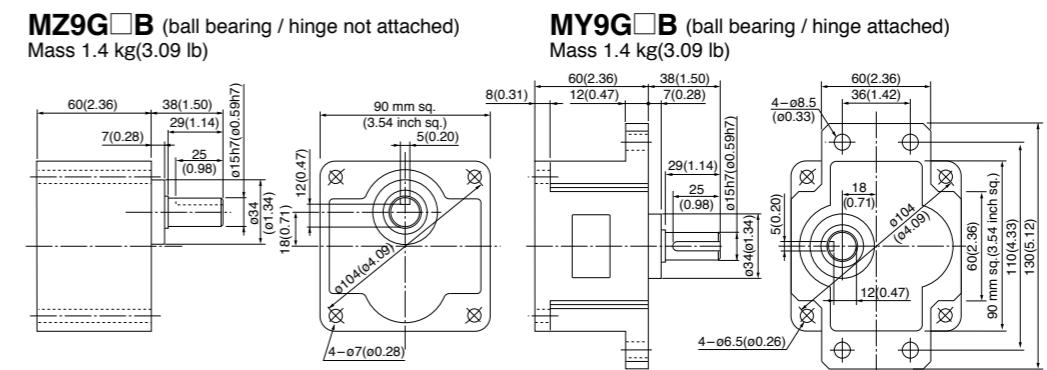

Note) MZ / MY is available for a gear head of either type.

(Note) Because the dimensions may be subject to change, also check the determinate dimensions if the gear head is to be used for design.

Gear head combination B-59 Round shaft motor B-62 Decimal gear head B-448 Gear head -inch (U.S.A.) B-449 Controls C-4 Option D-2

Induction motor (leadwire)

90 mm (3.54 inch) sq. 90 W

Specifications

Size	Motor model No.	Number of pole (P)	Output (W)	Voltage (V)	Frequency (Hz)	Rating (min)	Rating				Starting current (A)	Starting torque N-m (oz-in)	Capacitor (μF) (rated voltage)
							Input (W)	Current (A)	Speed (r/min)	Torque N-m (oz-in)			
90 mm sq.	M91Z90G4L	4	90	100	50	Cont.	153	1.6	1325	0.65 (92.0)	3.3	0.47 (66.6)	25 (200 V)
							160	1.6	1625	0.53 (75.1)	3.0	0.47 (66.6)	
	M91Z90G4Y	4	90	200	50	Cont.	150	0.75	1325	0.62 (87.8)	1.7	0.47 (66.6)	5.8 (400 V)
							160	0.80	1650	0.51 (72.2)	1.5	0.47 (66.6)	

* The specifications and wire connections of the round shaft motor are the same as those of the pinion shaft type. For the dimensional outline drawing, refer to page B-62.

Permissible torque at output shaft of gear head

* The speed shown below is a calculated value based on the synchronous rotational speed. Depending on the load, the speed is less than the indicated value by 2% to 20%.

Unit of permissible torque: upper (N·m) / lower (lb·in)

Reduction ratio		3	3.6	5	6	7.5	9	10	12.5	15	18	20	25	30	36	50	60	75	90	100	120	150	180	200		
Speed (r/min)		50 Hz	60 Hz	500	416.7	300	250	200	166.7	150	120	100	83.3	75	60	50	41.7	30	25	20	16.7	15	12.5	10	8.3	7.5
Applicable gear head	MZ9G3B to MZ9G200B (ball bearing / hinge not attached)	50 Hz	1.37 (12.1)	1.67 (14.8)	2.25 (19.9)	2.74 (24.3)	3.43 (30.4)	4.12 (36.5)	4.51 (39.9)	5.68 (50.3)	6.76 (59.8)	8.04 (71.2)	9.02 (79.8)	10.9 (96.5)	13.0 (115)	15.7 (139)	19.6 (173)									19.6 (173)
	MY9G3B to MY9G200B (ball bearing / hinge attached)	60 Hz	1.18 (10.4)	1.37 (12.1)	1.86 (16.5)	2.25 (19.9)	2.84 (25.1)	3.43 (30.4)	3.72 (32.9)	4.70 (41.6)	5.68 (50.3)	6.76 (59.8)	7.55 (66.8)	9.21 (81.5)	10.9 (96.5)	13.0 (115)	18.3 (162)									19.6 (173)
Rotational direction		Same as motor rotational direction						Reverse to motor rotational direction						Same as motor rotational direction												

Permissible torque at output shaft of gear head using decimal gear head

* For external dimensions of the decimal gear head, refer to page B-448.

Applicable gear head		Reduction ratio	250	300	360	500	600	750	900	1000	1200	1500	1800		
Bearing	Decimal gear head	Speed (r/min)	50 Hz	60 Hz	6	5	4.2	3	2.5	2	1.7	1.5	1.3	1	0.8
		MZ9G□B (ball bearing / hinge not attached)	MZ9G10XB	Permissible torque	19.6 (173)	19.6 (173)	19.6 (173)	19.6 (173)	19.6 (173)	19.6 (173)	19.6 (173)	19.6 (173)	19.6 (173)	19.6 (173)	19.6 (173)
MY9G□B (ball bearing / hinge attached)	Rotational direction	Reverse to motor rotational direction			Same as motor rotational direction										

Connection diagram

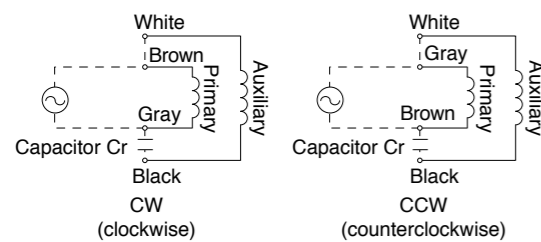

Speed-torque characteristics

M91Z90G4L

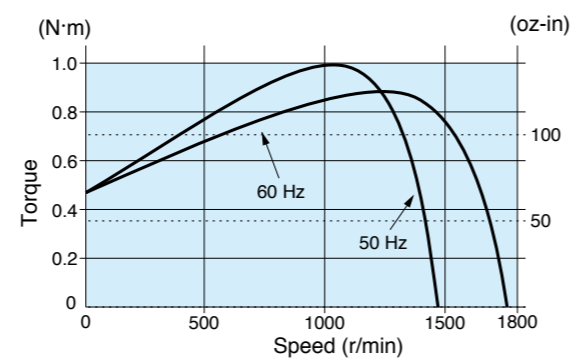

* Please read your User's manual carefully so that you will understand the operation and safety precautions before attempting to operate the system.

Features B-2 System configuration B-3 Coding system B-3 Model list B-4

Motor (dimensions)

M91Z90G4L 4P 90 W 100 V (with fan)
M91Z90G4Y 4P 90 W 200 V (with fan)

Scale: 1/4, Unit: mm (inch)

Mass 3.2 kg (7.05 lb)
Helical gear
Module 0.6
Number of teeth 9

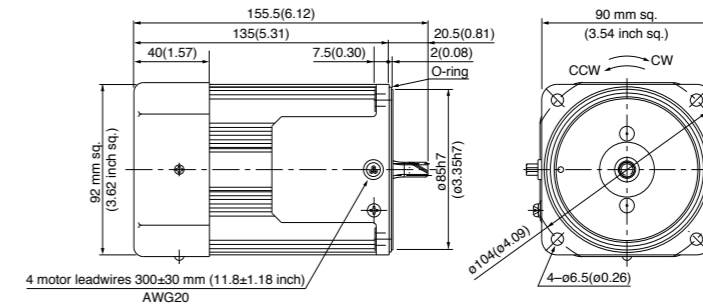

Capacitor (dimensions) [attachment]

Unit: mm (inch)

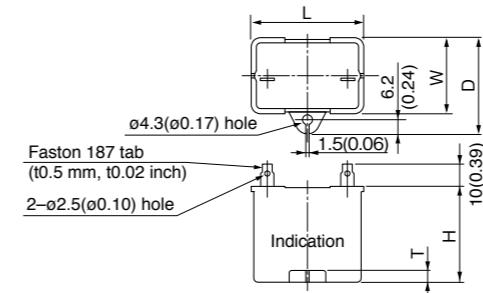

Capacitor cap (dimensions) [option]

Unit: mm (inch)

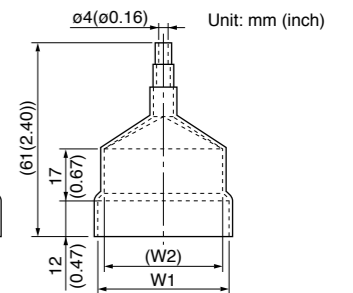

Capacitor dimension list

Model number of motor	Model number of capacitor (attachment)	L	W	D	H	T	Capacitor cap (option)	W1	W2	W3	W4
M91Z90G4L	M0PC25M20	50.2 (1.98)	31	41	42 (1.65)	5 (0.20)	M0PC5032	50 (1.97)	48 (1.89)	32.5 (1.28)	29.5 (1.16)
M91Z90G4Y	M0PC5.8M40	50 (1.97)	30.5 (1.20)	41 (1.61)	41.5 (1.63)	4 (0.16)	M0PC5032	50 (1.97)	48 (1.89)	32.5 (1.28)	29.5 (1.16)

* Capacitors (single item) can also be purchased.

Gear head (dimensions)

Scale: 1/4, Unit: mm (inch)

MZ9G□B (ball bearing / hinge not attached)
Mass 1.4 kg (3.09 lb)

MY9G□B (ball bearing / hinge attached)
Mass 1.4 kg (3.09 lb)

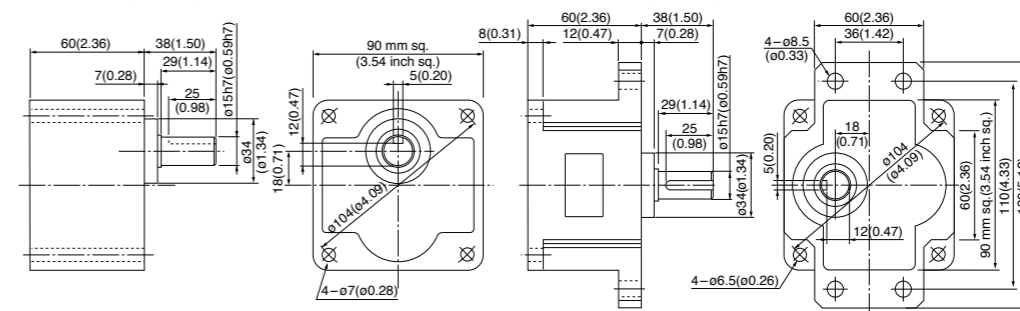

Note) MZ / MY is available for a gear head of either type.

(Note) Because the dimensions may be subject to change, also check the determinate dimensions if the gear head is to be used for design.

Gear head combination B-59 Round shaft motor B-62 Decimal gear head B-448 Gear head -inch (U.S.A.) B-449 Controls C-4 Option D-2

Key and keyway (dimensions) [attachment]

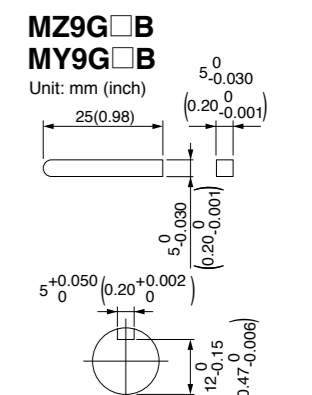

Induction motor (leadwire)

US CE CCC 90 mm (3.54 inch) sq. 90 W

Specifications

Size	Motor model No.	Number of pole (P)	Output (W)	Voltage (V)	Frequency (Hz)	Rating (min)	Rating			Starting current (A)	Starting torque N-m (oz-in)	Capacitor (μF) (rated voltage)
							Input (W)	Current (A)	Speed (r/min)			
90 mm sq.	M91Z90G4LG M91Z90G4LGA	4	90	100	50	Cont.	172	1.8	1250	0.69 (97.7)	3.0	0.65 (92.0)
							177	1.8	1575	0.55 (77.9)	2.8	0.65 (92.0)
	M91Z90G4DG M91Z90G4DGA	4	90	110	60	Cont.	168	1.6	1600	0.54 (76.5)	3.0	0.65 (92.0)
							176	1.6	1600	0.54 (76.5)	3.1	0.72 (102.0)
	M91Z90G4YG M91Z90G4YGA	4	90	200	50	Cont.	170	0.85	1225	0.70 (99.1)	1.4	0.65 (92.0)
							188	0.97	1550	0.55 (77.9)	1.4	0.65 (92.0)
	M91Z90G4GG M91Z90G4GGA	4	90	220	50	Cont.	176	0.85	1225	0.70 (99.1)	1.5	0.63 (89.2)
					60		167	0.76	1575	0.55 (77.9)	1.4	0.65 (92.0)
					50		185	0.89	1250	0.69 (97.7)	1.5	0.68 (96.3)
					60		173	0.76	1600	0.54 (76.5)	1.5	0.72 (102.0)
					230		153	0.70	1325	0.65 (92.0)	1.4	0.55 (77.9)
					60		169	0.81	1625	0.53 (75.1)	1.3	0.56 (79.3)
M91Z90G4GGB M91Z90G4GCC	4	90	220	50	Cont.	159	0.70	1350	0.64 (90.6)	1.5	0.61 (86.4)	
				60		176	0.81	1650	0.52 (73.6)	1.4	0.63 (89.2)	
				230		176	0.81	1650	0.52 (73.6)	1.4	0.63 (89.2)	

The specifications and wire connections of the round shaft motor are the same as those of the pinion shaft type. For the dimensional outline drawing, refer to page B-62.
 The models with a motor model number to which "A" is suffixed are not equipped with a capacitor cap.
 The models with a motor model number to which "A" is suffixed are not sold or available in Japan.

Permissible torque at output shaft of gear head

* The speed shown below is a calculated value based on the synchronous rotational speed. Depending on the load, the speed is less than the indicated value by 2% to 20%.

Unit of permissible torque: upper (N·m) / lower (lb-in)

Reduction ratio	Unit of permissible torque: upper (N·m) / lower (lb-in)																									
	3	3.6	5	6	7.5	9	10	12.5	15	18	20	25	30	36	50	60										
Speed (r/min)	50 Hz	500	416.7	300	250	200	166.7	150	120	100	83.3	75	60	50	41.7	30	25	20	16.7	15	12.5	10	8.3	7.5		
	60 Hz	600	500	360	300	240	200	180	144	120	100	90	72	60	50	36	30	24	20	18	15	12	10	9		
Applicable gear head	MZ9G3B to MZ9G200B (ball bearing / hinge not attached)	50 Hz	1.37	1.67	2.25	2.74	3.43	4.12	4.51	5.68	6.76	8.04	9.02	10.9	13.0	15.7	19.6									
	60 Hz	1.18	1.37	1.86	2.25	2.84	3.43	3.72	4.70	5.68	6.76	7.55	9.21	10.9	13.0	18.3	19.6									
Rotational direction	MZ9G3B to MY9G200B (ball bearing / hinge attached)	50 Hz	1.18	1.37	1.86	2.25	2.84	3.43	3.72	4.70	5.68	6.76	7.55	9.21	10.9	13.0	18.3	19.6								
	60 Hz	1.18	1.37	1.86	2.25	2.84	3.43	3.72	4.70	5.68	6.76	7.55	9.21	10.9	13.0	18.3	19.6									
Rotational direction	Same as motor rotational direction	Reverse to motor rotational direction																								

Permissible torque at output shaft of gear head using decimal gear head

* For external dimensions of the decimal gear head, refer to page B-448.

Applicable gear head		Reduction ratio	Permissible torque																	
Bearing	Decimal gear head		Speed (r/min)	50 Hz		60 Hz		7.5		9		10		12.5		15		18		20
		MZ9G□B (ball bearing / hinge not attached)		MZ9G10XB	Permissible torque															
N-m (lb-in)	19.6 (173)		19.6 (173)			19.6 (173)	19.6 (173)	19.6 (173)	19.6 (173)	19.6 (173)	19.6 (173)	19.6 (173)	19.6 (173)	19.6 (173)	19.6 (173)	19.6 (173)	19.6 (173)	19.6 (173)	19.6 (173)	19.6 (173)
MY9G□B (ball bearing / hinge attached)	MZ9G10XB	Permissible torque																		
			N-m (lb-in)	19.6 (173)	19.6 (173)	19.6 (173)	19.6 (173)	19.6 (173)	19.6 (173)	19.6 (173)	19.6 (173)	19.6 (173)	19.6 (173)	19.6 (173)	19.6 (173)	19.6 (173)	19.6 (173)	19.6 (173)	19.6 (173)	19.6 (173)
Rotational direction		Reverse to motor rotational direction	Same as motor rotational direction																	

Connection diagram

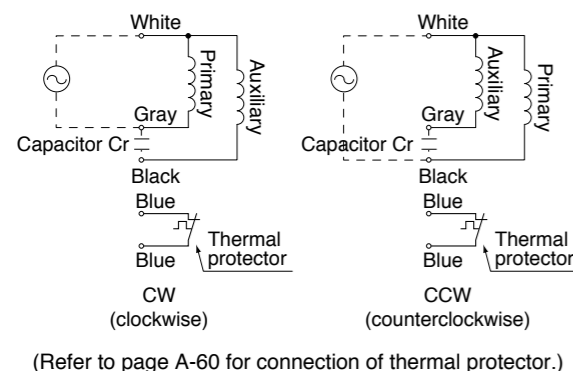

(Refer to page A-60 for connection of thermal protector.)

Speed-torque characteristics

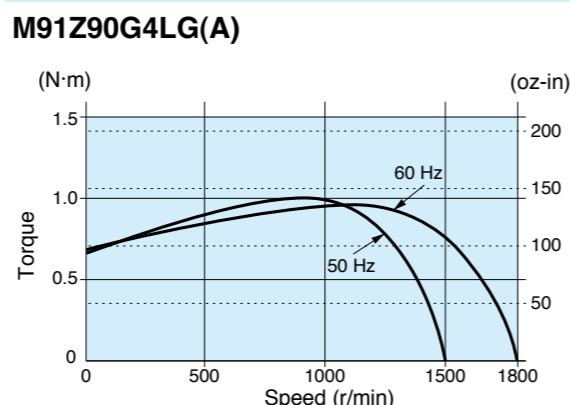

Motor (dimensions)

Scale: 1/4, Unit: mm (inch)

M91Z90G4LG(A) 4P 90 W 100 V (with fan)
 M91Z90G4DG(A) 4P 90 W 110 V / 115 V (with fan)
 M91Z90G4YG(A) 4P 90 W 200 V (with fan)
 M91Z90G4GG(A) 4P 90 W 220 V / 230 V (with fan)
 M91Z90G4GGB 4P 90 W 220 V / 230 V (with fan)
 M91Z90G4GCC 4P 90 W 220 V / 230 V (with fan)

Mass 3.2 kg 7.05 lb
 Helical gear
 Module 0.6
 Number of teeth 9

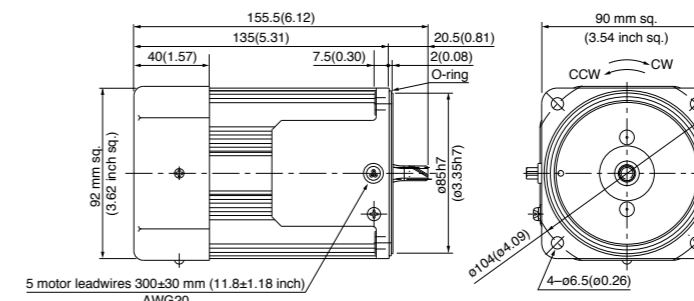

Capacitor (dimensions) [attachment]

Unit: mm (inch)

Capacitor cap (dimensions) [attachment]

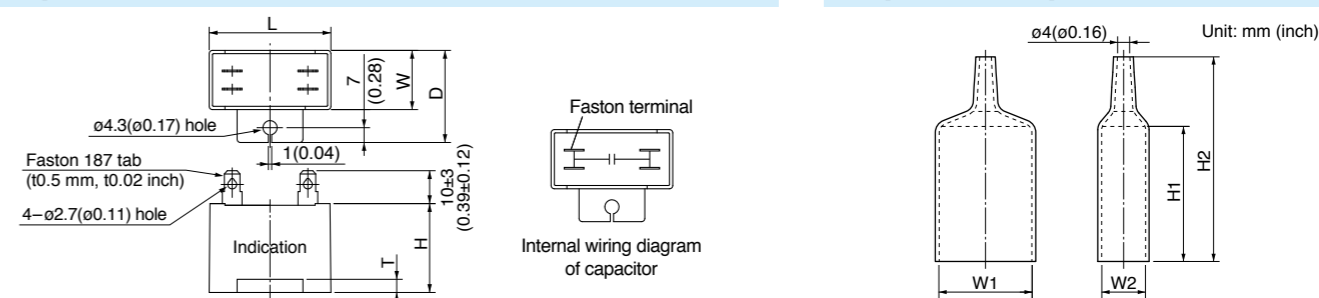

Capacitor dimension list Unit: upper (mm) / lower (inch)

Model number of motor	Model number of capacitor (attachment)	L	W	D	H	T	Capacitor cap (attachment)	W1	W2	H1	H2
M91Z90G4LG(A)	M0PC30M25G	58 (2.28)	35 (1.38)	50 (1.97)	50 (1.97)	4 (0.16)	M0PC5835G	58 (2.28)	35 (1.38)	55 (2.17)	78 (3.07)
M91Z90G4DG(A)	M0PC25M25G	58 (2.28)	35 (1.38)	50 (1.97)	50 (1.97)	4 (0.16)	M0PC5835G	58 (2.28)	35 (1.38)	55 (2.17)	78 (3.07)
M91Z90G4YG(A)	M0PC7.5M45G	58 (2.28)	35 (1.38)	50 (1.97)	50 (1.97)	4 (0.16)	M0PC5835G	58 (2.28)	35 (1.38)	55 (2.17)	78 (3.07)
M91Z90G4GG(A)	M0PC6M45G	58 (2.28)	35 (1.38)	50 (1.97)	50 (1.97)	4 (0.16)	M0PC5829G	58 (2.28)	29 (1.14)	55 (2.17)	78 (3.07)
M91Z90G4GGB											
M91Z90G4GCC											
M91Z90G4GCC											

* The models with a motor model number to which "A" or "B" is suffixed are not equipped with a capacitor cap.
 * Capacitors (single item), capacitors cap (single item) can also be purchased.

Gear head (dimensions)

Scale: 1/4, Unit: mm (inch)

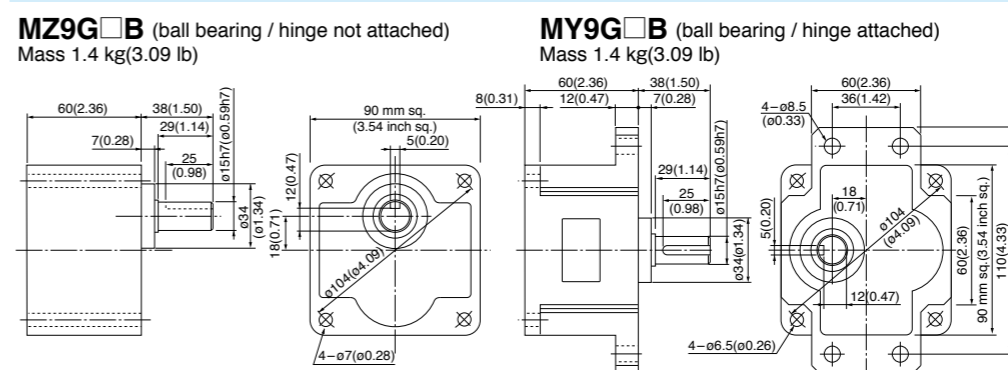

Note) MZ / MY is available for a gear head of either type.

Key and keyway (dimensions) [attachment]

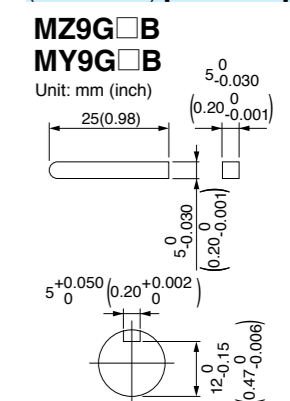

Note) Because the dimensions may be subject to change, also check the determinate dimensions if the gear head is to be used for design.

* Please read your User's manual carefully so that you will understand the operation and safety precautions before attempting to operate the system.

Features B-2 System configuration B-3 Coding system B-3 Model list B-4

Gear head combination B-59 Round shaft motor B-62 Decimal gear head B-448 Gear head -inch (U.S.A.) B-449 Controls C-4 Option D-2

Induction motor (sealed connector)

80 mm (3.15 inch) sq. 25 W

Specifications

Size	Motor model No.	Number of pole (P)	Output (W)	Voltage (V)	Frequency (Hz)	Rating (min)	Rating				Starting current (A)	Starting torque N-m (oz-in)	Capacitor (μF) (rated voltage)
							Input (W)	Current (A)	Speed (r/min)	Torque N-m (oz-in)			
80 mm sq.	M81X25GK4L	4	25	100	50	Cont.	51	0.55	1250	0.19 (26.9)	0.98	0.16 (22.7)	6 (200 V)
					60		49	0.48	1550	0.15 (21.2)	0.94	0.16 (22.7)	
	M81X25GK4Y	4	25	200	50	Cont.	51	0.27	1250	0.19 (26.9)	0.50	0.16 (22.7)	1.5 (400 V)
					60		49	0.24	1575	0.15 (21.2)	0.47	0.16 (22.7)	

* The specifications and wire connections of the round shaft motor are the same as those of the pinion shaft type. For the dimensional outline drawing, refer to page B-62.

Permissible torque at output shaft of gear head

* The speed shown below is a calculated value based on the synchronous rotational speed. Depending on the load, the speed is less than the indicated value by 2% to 20%.

Unit of permissible torque: upper (N·m) / lower (lb·in)

Reduction ratio	Unit of permissible torque: upper (N·m) / lower (lb·in)																							
	3	3.6	5	6	7.5	9	10	12.5	15	18	20	25	30	36	50	60	75	90	100	120	150	180		
Speed (r/min)																								
	50 Hz	500	416.7	300	250	200	166.7	150	120	100	83.3	75	60	50	41.7	30	25	20	16.7	15	12.5	10	8.3	
	60 Hz	600	500	360	300	240	200	180	144	120	100	90	72	60	50	36	30	24	20	18	15	12	10	
Applicable gear head	MX8G3B to MX8G180B (ball bearing)	50 Hz	0.39 (3.45)	0.47 (4.16)	0.66 (5.84)	0.78 (6.90)	0.98 (8.67)	1.18 (10.4)	1.27 (11.2)	1.57 (13.9)	1.96 (17.3)	2.35 (20.8)	2.55 (22.6)	3.14 (27.8)	3.82 (33.8)	4.61 (40.8)	6.37 (56.4)	7.64 (67.6)						7.84 (69.4)
		60 Hz	0.32 (2.83)	0.39 (3.45)	0.55 (4.87)	0.66 (5.84)	0.81 (7.17)	0.98 (8.67)	1.08 (9.56)	1.27 (11.2)	1.57 (13.9)	1.96 (17.3)	2.06 (18.2)	2.65 (23.5)	3.14 (27.8)	3.82 (33.8)	5.29 (46.8)	6.37 (56.4)						7.84 (69.4)
Rotational direction		Same as motor rotational direction											Reverse to motor rotational direction											

Permissible torque at output shaft of gear head using decimal gear head

* For external dimensions of the decimal gear head, refer to page B-448.

Applicable gear head	Reduction ratio	Permissible torque												
		200	250	300	360	500	600	750	900	1000	1200	1500	1800	
Bearing	Decimal gear head	50 Hz	7.5	6	5	4.2	3	2.5	2	1.7	1.5	1.3	1	0.8
		60 Hz	9	7.2	6	5	3.6	3	2.4	2	1.8	1.5	1.2	1
MX8G□B (ball bearing)	MX8G10XB	Permissible torque	N·m	7.84	7.84	7.84	7.84	7.84	7.84	7.84	7.84	7.84	7.84	7.84
			(lb·in)	(69.4)	(69.4)	(69.4)	(69.4)	(69.4)	(69.4)	(69.4)	(69.4)	(69.4)	(69.4)	(69.4)
Rotational direction		Same as motor rotational direction / Reverse to motor rotational direction												

Connection diagram

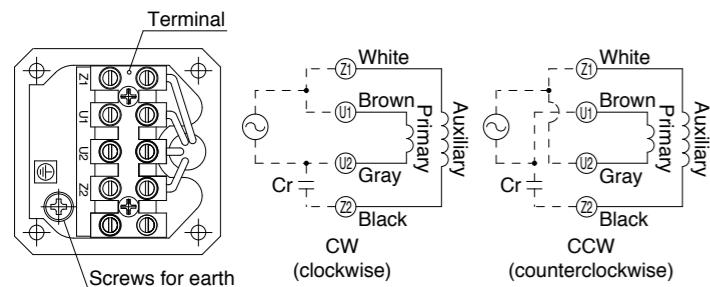

Speed-torque characteristics

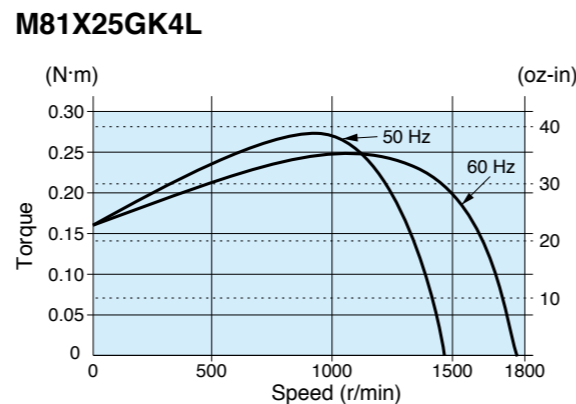

* Please read your User's manual carefully so that you will understand the operation and safety precautions before attempting to operate the system.

- Features B-2
- System configuration B-3
- Coding system B-3
- Model list B-4

Motor (dimensions)

Scale: 1/3, Unit: mm (inch)

M81X25GK4L	4P 25 W 100 V
M81X25GK4Y	4P 25 W 200 V

Mass	1.8 kg (3.97 lb)	Helical gear	Module	0.5	Number of teeth	9
------	------------------	--------------	--------	-----	-----------------	---

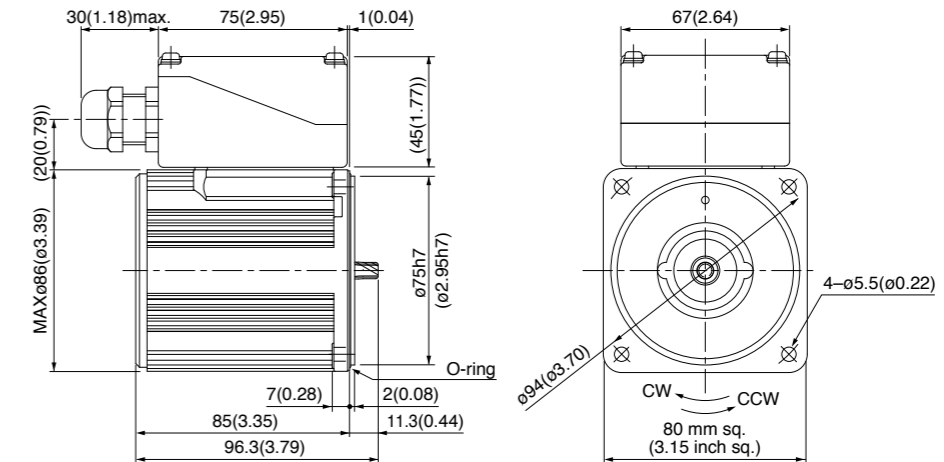

* Diameter of applicable cable to be ø8(ø0.31) to ø12(ø0.47).

Capacitor (dimensions) [attachment]

Unit: mm (inch)

Capacitor cap (dimensions) [option]

Unit: mm (inch)

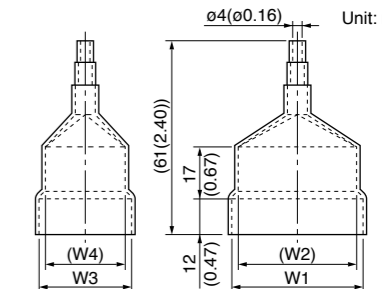
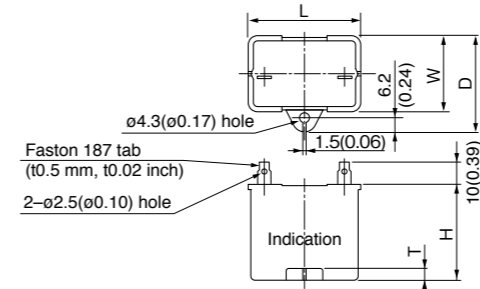

Capacitor dimension list

Unit: upper (mm) / lower (inch)

Model number of motor	Model number of capacitor (attachment)	L	W	D	H	T	Capacitor cap (option)	W1	W2	W3	W4
M81X25GK4L	M0PC6M20	39.5 (1.56)	17.5 (0.69)	28 (1.10)	30.5 (1.20)	4 (0.16)	M0PC3917	39.5 (1.56)	37.5 (1.48)	17 (0.67)	15 (0.59)
M81X25GK4Y	M0PC1.5M40	39.5 (1.56)	22 (0.87)	32.5 (1.28)	32.5 (1.28)	4 (0.16)	M0PC3922	39.5 (1.56)	37.5 (1.48)	22 (0.87)	20 (0.79)

* Capacitors (single item) can also be purchased.

Gear head (dimensions)

Scale: 1/3, Unit: mm (inch)

MX8G□B (ball bearing) Mass 0.6 kg (1.32 lb)

MX8G□M (metal bearing) Mass 0.6 kg (1.32 lb)

Key and keyway (dimensions) [attachment]

MX8G□B(M)

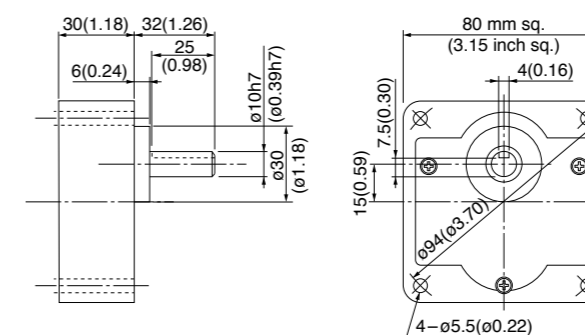
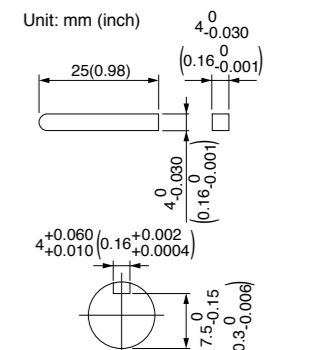

(Note) Because the dimensions may be subject to change, also check the determinate dimensions if the gear head is to be used for design.

- Gear head combination B-60
- Round shaft motor B-62
- Decimal gear head B-448
- Gear head -inch (U.S.A.) B-449
- Controls C-4
- Option D-2

Specifications

Size	Motor model No.	Number of pole (P)	Output (W)	Voltage (V)	Frequency (Hz)	Rating (min)	Rating			Starting current (A)	Starting torque N-m (oz-in)	Capacitor (μF) (rated voltage)	
							Input (W)	Current (A)	Speed (r/min)				
80 mm sq.	M81X25GK4LG(A) M81X25GK4LGA	4	25	100	50	Cont.	55	0.59	1250	0.19 (26.9)	1.1	0.16 (22.7)	8 (250 V)
				110	60	Cont.	50	0.50	1575	0.15 (21.2)	1.0	0.16 (22.7)	
	M81X25GK4DG(A) M81X25GK4DGA	4	25	110	60	Cont.	52	0.50	1575	0.15 (21.2)	1.1	0.14 (19.8)	6 (250 V)
				115	60	Cont.	53	0.50	1600	0.15 (21.2)	1.1	0.15 (21.2)	
	M81X25GK4YG(A) M81X25GK4YGA	4	25	200	50	Cont.	54	0.27	1200	0.20 (28.3)	0.43	0.16 (22.7)	2.1 (450 V)
				230	60	Cont.	54	0.27	1550	0.15 (21.2)	0.42	0.16 (22.7)	
	M81X25GK4GG(A) M81X25GK4GGA	4	25	220	50	Cont.	59	0.29	1200	0.20 (28.3)	0.46	0.15 (21.2)	1.5 (450 V)
				230	60	Cont.	51	0.23	1550	0.15 (21.2)	0.44	0.15 (21.2)	
				230	50	Cont.	59	0.28	1250	0.19 (26.9)	0.48	0.16 (22.7)	
				230	60	Cont.	52	0.23	1575	0.15 (21.2)	0.45	0.16 (22.7)	

The specifications and wire connections of the round shaft motor are the same as those of the pinion shaft type. For the dimensional outline drawing, refer to page B-62.
The models with a motor model number to which "A" is suffixed are not equipped with a capacitor cap.
The models with a motor model number to which "A" is suffixed are not sold or available in Japan.

Permissible torque at output shaft of gear head

* The speed shown below is a calculated value based on the synchronous rotational speed. Depending on the load, the speed is less than the indicated value by 2% to 20%.

Reduction ratio	3	3.6	5	6	7.5	9	10	12.5	15	18	20	25	30	36	50	60	75	90	100	120	150	180	
Speed (r/min)	50 Hz 600	416.7 500	300 360	250 300	200 240	166.7 200	150 180	120 144	100 120	83.3 100	75 90	60 72	50 60	41.7 50	30 36	25 30	20 24	16.7 20	15 18	12.5 15	10 12	8.3 10	
Applicable gear head	MX8G3B to MX8G180B (ball bearing)	0.39	0.47	0.66	0.78	0.98	1.18	1.27	1.57	1.96	2.35	2.55	3.14	3.82	4.61	6.37	7.64						7.84
		(3.45)	(4.16)	(5.84)	(6.90)	(8.67)	(10.4)	(11.2)	(13.9)	(17.3)	(20.8)	(22.6)	(27.8)	(33.8)	(40.8)	(56.4)	(67.6)						
	MX8G3M to MX8G180M (metal bearing)	0.32	0.39	0.55	0.66	0.81	0.98	1.08	1.27	1.57	1.96	2.06	2.65	3.14	3.82	5.29	6.37						7.84
		(2.83)	(3.45)	(4.87)	(5.84)	(7.17)	(8.67)	(9.56)	(11.2)	(13.9)	(17.3)	(18.2)	(23.5)	(27.8)	(33.8)	(46.8)	(56.4)						
Rotational direction	Same as motor rotational direction										Reverse to motor rotational direction												

Permissible torque at output shaft of gear head using decimal gear head

* For external dimensions of the decimal gear head, refer to page B-448.

Applicable gear head	Reduction ratio	200	250	300	360	500	600	750	900	1000	1200	1500	1800
Bearing	50 Hz	7.5	6	5	4.2	3	2.5	2	1.7	1.5	1.3	1	0.8
	60 Hz	9	7.2	6	5	3.6	3	2.4	2	1.8	1.5	1.2	1
MX8G□B (ball bearing) MX8G□M (metal bearing)	MX8G10XB	Permissible torque	N·m	7.84	7.84	7.84	7.84	7.84	7.84	7.84	7.84	7.84	7.84
		(lb-in)	(69.4)	(69.4)	(69.4)	(69.4)	(69.4)	(69.4)	(69.4)	(69.4)	(69.4)	(69.4)	(69.4)
Rotational direction		Same as motor rotational direction						Reverse to motor rotational direction					

Connection diagram

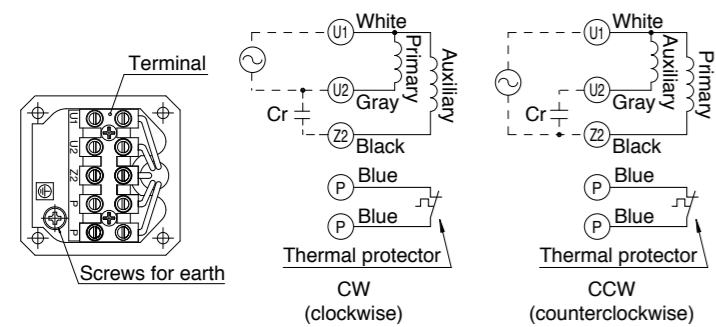

(Refer to page A-60 for connection of thermal protector.)

Speed-torque characteristics

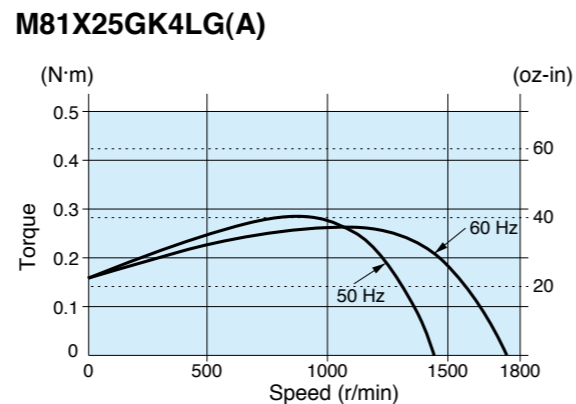

Motor (dimensions)

Scale: 1/3, Unit: mm (inch)

M81X25GK4LG(A)	4P 25 W 100 V
M81X25GK4DG(A)	4P 25 W 110 V / 115 V
M81X25GK4YG(A)	4P 25 W 200 V
M81X25GK4GG(A)	4P 25 W 220 V / 230 V

Mass	1.8 kg 3.97 lb
Helical gear	
Module	0.5
Number of teeth	9

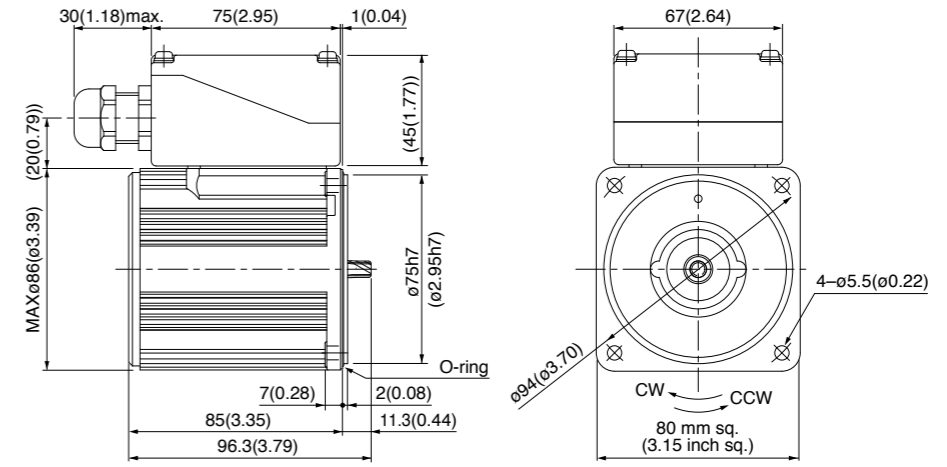

* Diameter of applicable cable to be ø8(ø0.31) to ø12(ø0.47).

Capacitor (dimensions) [attachment]

Unit: mm (inch)

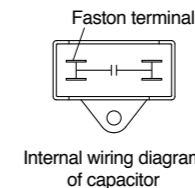
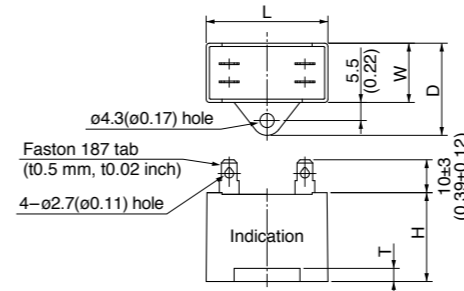

Capacitor cap (dimensions) [attachment]

Unit: mm (inch)

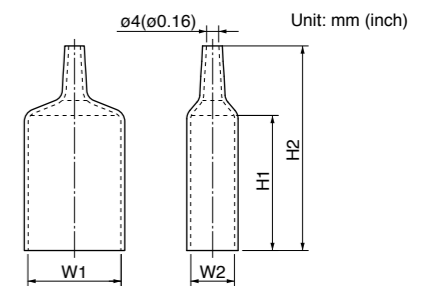

Capacitor dimension list

Unit: upper (mm) / lower (inch)

Model number of motor	Model number of capacitor (attachment)	L	W	D	H	T	Capacitor cap (attachment)	W1	W2	H1	H2
M81X25GK4LG(A)	M0PC8M25G	48 (1.89)	21 (0.83)	31 (1.22)	31 (1.22)	4 (0.16)	M0PC4821G	48 (1.89)	21 (0.83)	55 (2.17)	78 (3.07)
M81X25GK4DG(A)	M0PC6M25G	38 (1.50)	21 (0.83)	31 (1.22)	31 (1.22)	4 (0.16)	M0PC3821G	38 (1.50)	21 (0.83)	55 (2.17)	78 (3.07)
M81X25GK4YG(A)	M0PC2.1M45G	48 (1.89)	21 (0.83)	31 (1.22)	31 (1.22)	4 (0.16)	M0PC4821G	48 (1.89)	21 (0.83)	55 (2.17)	78 (3.07)
M81X25GK4GG(A)	M0PC1.5M45G	38 (1.50)	21 (0.83)	31 (1.22)	31 (1.22)	4 (0.16)	M0PC3821G	38 (1.50)	21 (0.83)	55 (2.17)	78 (3.07)

* The models with a motor model number to which "A" is suffixed are not equipped with a capacitor cap.
* Capacitors (single item), capacitors cap (single item) can also be purchased.

Gear head (dimensions)

Scale: 1/3, Unit: mm (inch)

MX8G□B (ball bearing) Mass 0.6 kg(1.32 lb)

MX8G□M (metal bearing) Mass 0.6 kg(1.32 lb)

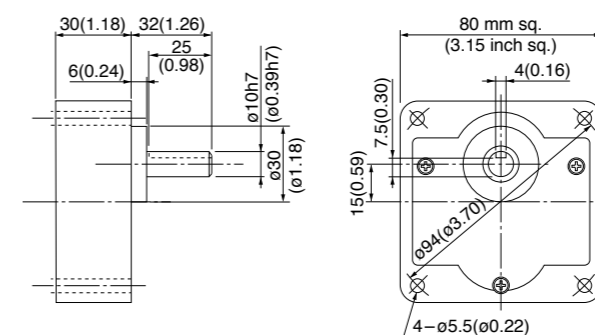

Key and keyway (dimensions) [attachment]

MX8G□B(M)

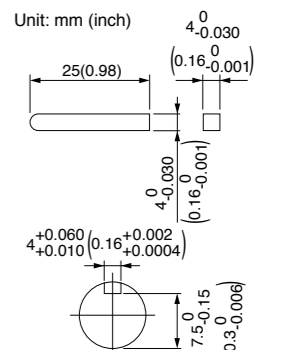

(Note) Because the dimensions may be subject to change, also check the determinate dimensions if the gear head is to be used for design.

Features B-2 System configuration B-3 Coding system B-3 Model list B-4 Gear head combination B-60 Round shaft motor B-62 Decimal gear head B-448 Gear head -inch (U.S.A.) B-449 Controls C-4 Option D-2

Induction motor (sealed connector)

90 mm (3.54 inch) sq. 40 W

Specifications

Size	Motor model No.	Number of pole (P)	Output (W)	Voltage (V)	Frequency (Hz)	Rating (min)	Rating				Starting current (A)	Starting torque N-m (oz-in)	Capacitor (μF) (rated voltage)
							Input (W)	Current (A)	Speed (r/min)	Torque N-m (oz-in)			
90 mm sq.	M91X40GK4L	4	40	100	50	Cont.	78	0.86	1225	0.30 (42.5)	1.5	0.24 (34.0)	10 (200 V)
							72	0.72	1550	0.25 (35.4)	1.5	0.25 (35.4)	
	M91X40GK4Y	4	40	200	60	Cont.	79	0.43	1250	0.30 (42.5)	0.83	0.25 (35.4)	2.5 (400 V)
							72	0.36	1575	0.24 (34.0)	0.76	0.25 (35.4)	

* The specifications and wire connections of the round shaft motor are the same as those of the pinion shaft type. For the dimensional outline drawing, refer to page B-62.

Permissible torque at output shaft of gear head

* The speed shown below is a calculated value based on the synchronous rotational speed. Depending on the load, the speed is less than the indicated value by 2% to 20%.

Unit of permissible torque: upper (N·m) / lower (lb-in)

Reduction ratio	Speed (r/min)																								
	50 Hz	60 Hz	3	3.6	5	6	7.5	9	10	12.5	15	18	20	25	30	36	50	60	75	90	100	120	150	180	
50 Hz	0.66 (5.84)	0.78 (6.90)	1.08 (9.56)	1.27 (11.2)	1.57 (13.9)	1.86 (16.5)	2.25 (19.9)	2.74 (24.3)	3.23 (28.6)	3.92 (34.7)	4.41 (39.0)	5.29 (46.8)	6.37 (56.4)	7.94 (70.3)	9.80 (86.7)										
60 Hz	0.55 (4.87)	0.66 (5.84)	0.90 (7.97)	1.08 (9.56)	1.27 (11.2)	1.57 (13.9)	1.76 (15.6)	2.25 (19.9)	2.74 (24.3)	3.23 (28.6)	3.53 (31.2)	4.41 (39.0)	5.29 (46.8)	6.37 (56.4)	8.82 (78.1)										

Rotational direction: Same as motor rotational direction / Reverse to motor rotational direction

Permissible torque at output shaft of gear head using decimal gear head

* For external dimensions of the decimal gear head, refer to page B-448.

Applicable gear head	Reduction ratio	Speed (r/min)														
		200	250	300	360	500	600	750	900	1000	1200	1500	1800			
MX9G□B (ball bearing) MX9G□M (metal bearing)	MX9G10XB	Permissible torque	9.80 (86.7)	9.80 (86.7)	9.80 (86.7)	9.80 (86.7)	9.80 (86.7)	9.80 (86.7)	9.80 (86.7)	9.80 (86.7)	9.80 (86.7)	9.80 (86.7)	9.80 (86.7)	9.80 (86.7)	9.80 (86.7)	9.80 (86.7)
		Rotational direction	Same as motor rotational direction / Reverse to motor rotational direction													

Connection diagram

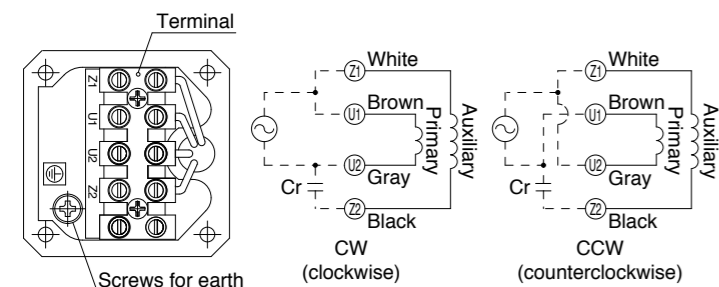

Speed-torque characteristics

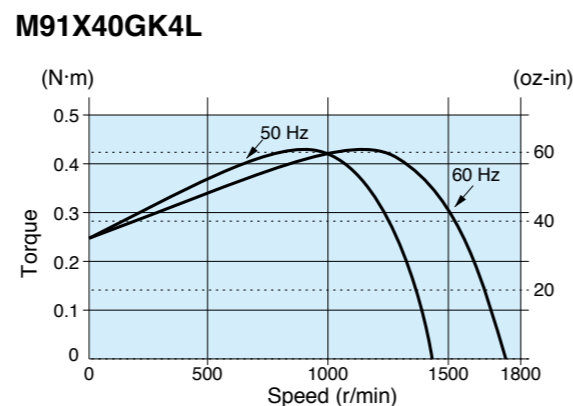

* Please read your User's manual carefully so that you will understand the operation and safety precautions before attempting to operate the system.

Features B-2 System configuration B-3 Coding system B-3 Model list B-4

Motor (dimensions)

Scale: 1/3, Unit: mm (inch)

M91X40GK4L 4P 40 W 100 V
M91X40GK4Y 4P 40 W 200 V

Mass 2.8 kg 6.17 lb
Helical gear
Module 0.55
Number of teeth 9

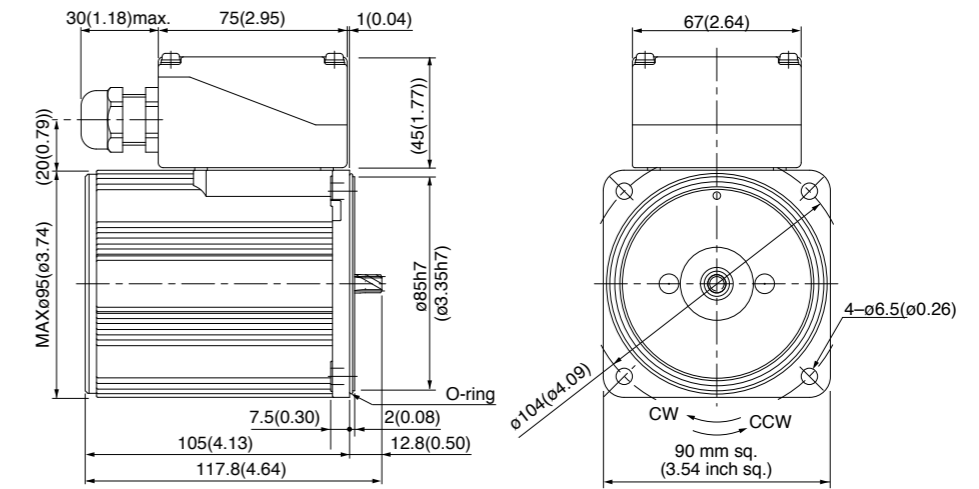

* Diameter of applicable cable to be ø8(ø0.31) to ø12(ø0.47).

Capacitor (dimensions) [attachment]

Unit: mm (inch)

Capacitor cap (dimensions) [option]

Unit: mm (inch)

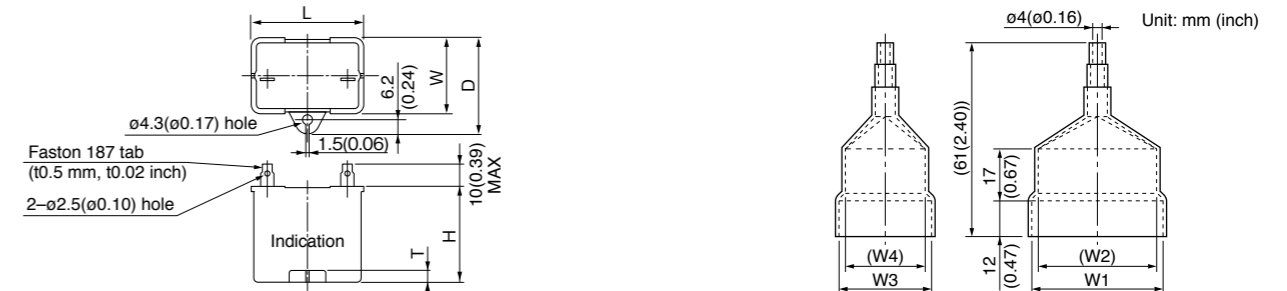

Capacitor dimension list

Unit: upper (mm) / lower (inch)

Model number of motor	Model number of capacitor (attachment)	L	W	D	H	T	Capacitor cap (option)	W1	W2	W3	W4
M91X40GK4L	M0PC10M20	39.5 (1.56)	26.7 (1.05)	37 (1.46)	32 (1.26)	4 (0.16)	M0PC3926	39.5 (1.56)	37.5 (1.48)	26 (1.02)	25 (0.98)
M91X40GK4Y	M0PC2.5M40	49.7 (1.96)	24 (0.94)	34.5 (1.36)	34.5 (1.36)	4 (0.16)	M0PC5026	50 (1.97)	48 (1.89)	26 (1.02)	22 (0.87)

* Capacitors (single item) can also be purchased.

Gear head (dimensions)

Scale: 1/3, Unit: mm (inch)

MX9G□B (ball bearing) Mass 0.8 kg (1.76 lb) MX9G□M (metal bearing) Mass 0.8 kg (1.76 lb)

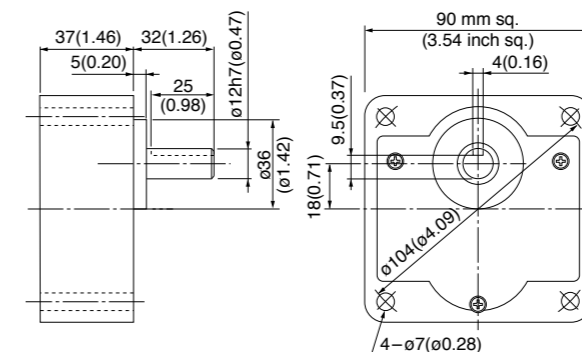

Key and keyway (dimensions) [attachment]

Unit: mm (inch)

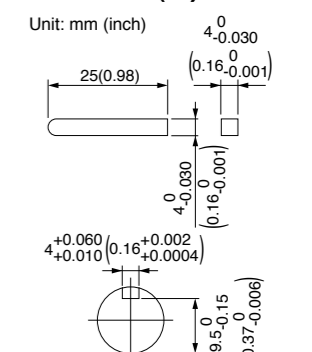

(Note) Because the dimensions may be subject to change, also check the determinate dimensions if the gear head is to be used for design.

Gear head combination B-60 Round shaft motor B-62 Decimal gear head B-448 Gear head -inch (U.S.A.) B-449 Controls C-4 Option D-2

Induction motor (sealed connector)

UL US CE CCC 90 mm (3.54 inch) sq. 40 W

• Specifications

Size	Motor model No.	Number of pole (P)	Output (W)	Voltage (V)	Frequency (Hz)	Rating (min)	Rating				Starting current (A)	Starting torque N-m (oz-in)	Capacitor (μF) (rated voltage)
							Input (W)	Current (A)	Speed (r/min)	Torque N-m (oz-in)			
90 mm sq.	M91X40GK4LG M91X40GK4LGA	4	40	100	50	Cont.	76	0.83	1250	0.31 (43.9)	1.7	0.26 (36.8)	12 (250 V)
							70	0.70	1600	0.24 (34.0)	1.5	0.26 (36.8)	
	M91X40GK4DG M91X40GK4DGA	4	40	110	60	Cont.	72	0.67	1625	0.24 (34.0)	1.7	0.26 (36.8)	10 (250 V)
							74	0.68	1625	0.24 (34.0)	1.8	0.27 (38.2)	
	M91X40GK4YG M91X40GK4YGA	4	40	200	50	Cont.	77	0.39	1175	0.33 (46.7)	0.64	0.26 (36.8)	3 (450 V)
							77	0.39	1525	0.25 (35.4)	0.62	0.26 (36.8)	
	M91X40GK4GG M91X40GK4GGA	4	40	220	50	Cont.	78	0.37	1250	0.31 (43.9)	0.69	0.26 (36.8)	2.5 (450 V)
					60		74	0.34	1575	0.24 (34.0)	0.65	0.26 (36.8)	
					50		79	0.37	1275	0.30 (42.5)	0.72	0.28 (39.6)	
					60		77	0.33	1600	0.24 (34.0)	0.68	0.28 (39.6)	

• The specifications and wire connections of the round shaft motor are the same as those of the pinion shaft type. For the dimensional outline drawing, refer to page B-62.
• The models with a motor model number to which "A" is suffixed are not equipped with a capacitor cap.
• The models with a motor model number to which "A" is suffixed are not sold or available in Japan.

• Permissible torque at output shaft of gear head

* The speed shown below is a calculated value based on the synchronous rotational speed. Depending on the load, the speed is less than the indicated value by 2% to 20%.

Unit of permissible torque: upper (N·m) / lower (lb-in)

Reduction ratio	3	3.6	5	6	7.5	9	10	12.5	15	18	20	25	30	36	50	60	75	90	100	120	150	180	
Speed (r/min)	50 Hz	500	416.7	300	250	200	166.7	150	120	100	83.3	75	60	50	41.7	30	25	20	16.7	15	12.5	10	8.3
	60 Hz	600	500	360	300	240	200	180	144	120	100	90	72	60	50	36	30	24	20	18	15	12	10
Applicable gear head	MX9G3B to MX9G180B (ball bearing)	50 Hz	0.66 (5.84)	0.78 (6.90)	1.08 (9.56)	1.27 (11.2)	1.57 (13.9)	1.86 (16.5)	2.25 (19.9)	2.74 (24.3)	3.23 (28.6)	3.92 (34.7)	4.41 (39.0)	5.29 (46.8)	6.37 (56.4)	7.94 (70.3)	9.80 (86.7)						
	MX9G3M to MX9G180M (metal bearing)	60 Hz	0.55 (4.87)	0.66 (5.84)	0.90 (7.97)	1.08 (9.56)	1.27 (11.2)	1.57 (13.9)	1.76 (15.6)	2.25 (19.9)	2.74 (24.3)	3.23 (28.6)	3.53 (31.2)	4.41 (39.0)	5.29 (46.8)	6.37 (56.4)	8.82 (78.1)						
Rotational direction	Same as motor rotational direction											Reverse to motor rotational direction											

• Permissible torque at output shaft of gear head using decimal gear head

* For external dimensions of the decimal gear head, refer to page B-448.

Applicable gear head		Reduction ratio	200	250	300	360	500	600	750	900	1000	1200	1500	1800	
Bearing	Decimal gear head	Speed (r/min)	50 Hz	7.5	6	5	4.2	3	2.5	2	1.7	1.5	1.3	1	0.8
		60 Hz	9	7.2	6	5	3.6	3	2.4	2	1.8	1.5	1.2	1	
MX9G□B (ball bearing)	MX9G10XB	Permissible torque	N·m (lb-in)	9.80 (86.7)	9.80 (86.7)	9.80 (86.7)	9.80 (86.7)	9.80 (86.7)	9.80 (86.7)	9.80 (86.7)	9.80 (86.7)	9.80 (86.7)	9.80 (86.7)	9.80 (86.7)	
MX9G□M (metal bearing)		Rotational direction	Same as motor rotational direction			Reverse to motor rotational direction									

Connection diagram

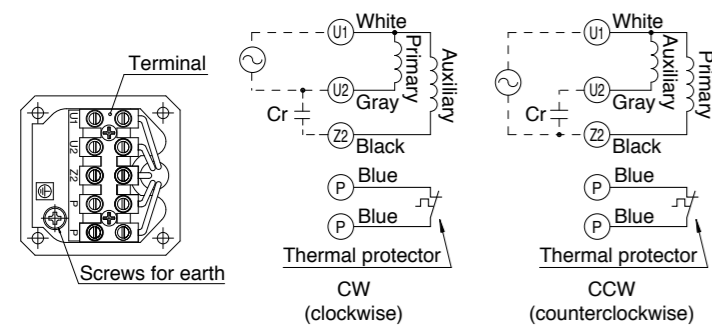

(Refer to page A-60 for connection of thermal protector.)

Speed-torque characteristics

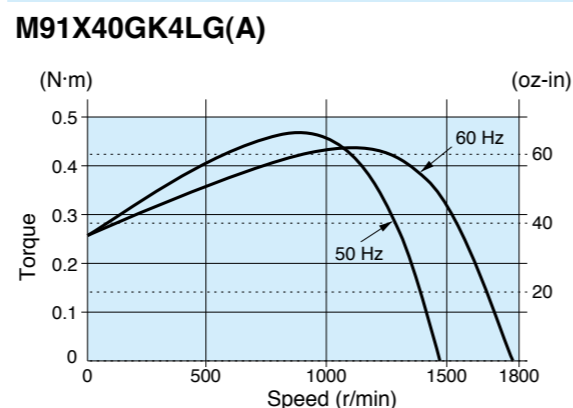

Motor (dimensions)

Scale: 1/3, Unit: mm (inch)

M91X40GK4LG(A) 4P 40 W 100 V
 M91X40GK4DG(A) 4P 40 W 110 V / 115 V
 M91X40GK4YG(A) 4P 40 W 200 V
 M91X40GK4GG(A) 4P 40 W 220 V / 230 V

Mass 2.8 kg 6.17 lb
 Helical gear
 Module 0.55
 Number of teeth 9

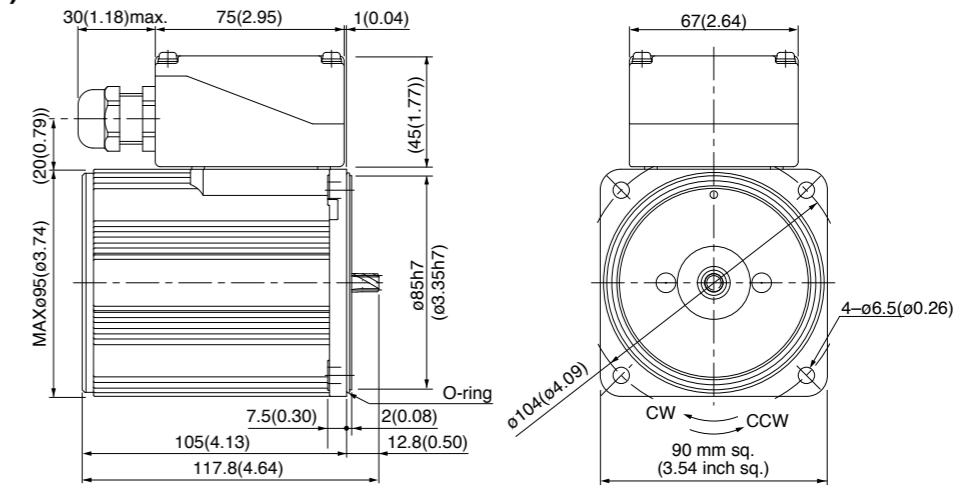

* Diameter of applicable cable to be ø8(ø0.31) to ø12(ø0.47).

Capacitor (dimensions) [attachment]

Unit: mm (inch)

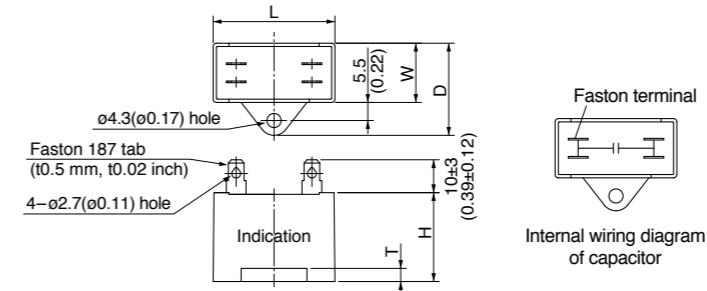

Capacitor cap (dimensions) [attachment]

Unit: mm (inch)

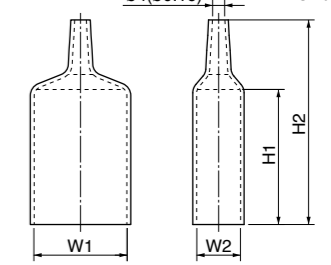

• Capacitor dimension list

Unit: upper (mm) / lower (inch)

Model number of motor	Model number of capacitor (attachment)	L	W	D	H	T	Capacitor cap (attachment)	W1	W2	H1	H2
M91X40GK4LG(A)	M0PC12M25G	58 (2.28)	22 (0.87)	32 (1.26)	35 (1.38)	4 (0.16)	M0PC5822G	58 (2.28)	22 (0.87)	55 (2.17)	78 (3.07)
M91X40GK4DG(A)	M0PC10M25G	58 (2.28)	21 (0.83)	31 (1.22)	31 (1.22)	4 (0.16)	M0PC5821G	58 (2.28)	21 (0.83)	55 (2.17)	78 (3.07)
M91X40GK4YG(A)	M0PC3M45G	58 (2.28)	21 (0.83)	31 (1.22)	31 (1.22)	4 (0.16)	M0PC5821G	58 (2.28)	21 (0.83)	55 (2.17)	78 (3.07)
M91X40GK4GG(A)	M0PC2.5M45G	48 (1.89)	21 (0.83)	31 (1.22)	31 (1.22)	4 (0.16)	M0PC4821G	48 (1.89)	21 (0.83)	55 (2.17)	78 (3.07)

* The models with a motor model number to which "A" is suffixed are not equipped with a capacitor cap.
 * Capacitors (single item), capacitors cap (single item) can also be purchased.

Gear head (dimensions)

Scale: 1/3, Unit: mm (inch)

MX9G□B (ball bearing) Mass 0.8 kg (1.76 lb) MX9G□M (metal bearing) Mass 0.8 kg (1.76 lb)

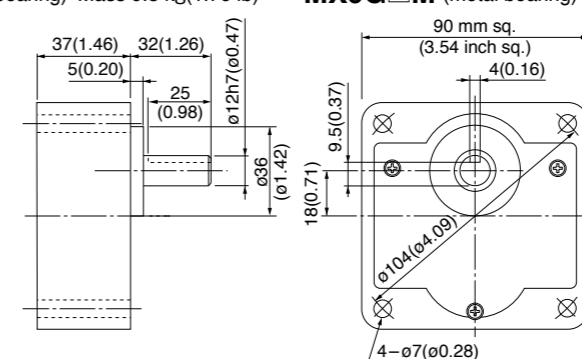

Key and keyway (dimensions) [attachment]

MX9G□B(M)

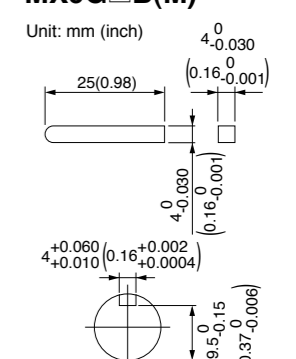

(Note) Because the dimensions may be subject to change, also check the determinate dimensions if the gear head is to be used for design.

* Please read your User's manual carefully so that you will understand the operation and safety precautions before attempting to operate the system.

Features B-2 System configuration B-3 Coding system B-3 Model list B-4

Gear head combination B-60 Round shaft motor B-62 Decimal gear head B-448 Gear head -inch (U.S.A.) B-449 Controls C-4 Option D-2

Induction motor (sealed connector)

90 mm (3.54 inch) sq. 60 W

Specifications

Size	Motor model No.	Number of pole (P)	Output (W)	Voltage (V)	Frequency (Hz)	Rating (min)	Rating				Starting current (A)	Starting torque N-m (oz-in)	Capacitor (μF) (rated voltage)
							Input (W)	Current (A)	Speed (r/min)	Torque N-m (oz-in)			
90 mm sq.	M91Z60GK4L	4	60	100	50	Cont.	118	1.3	1250	0.46 (65.1)	2.2	0.41 (58.1)	15 (210 V)
							117	1.2	1550	0.36 (51.0)	2.2	0.42 (59.5)	
	M91Z60GK4Y	4	60	200	50	Cont.	120	0.65	1250	0.46 (65.1)	1.1	0.42 (59.5)	3.8 (400 V)
							119	0.59	1550	0.36 (51.0)	1.1	0.44 (62.3)	

* The specifications and wire connections of the round shaft motor are the same as those of the pinion shaft type. For the dimensional outline drawing, refer to page B-62.

Permissible torque at output shaft of gear head

* The speed shown below is a calculated value based on the synchronous rotational speed. Depending on the load, the speed is less than the indicated value by 2% to 20%.

Unit of permissible torque: upper (N·m) / lower (lb-in)

Reduction ratio	Speed (r/min)																									
	50 Hz	60 Hz	500	416.7	300	250	200	166.7	150	120	100	83.3	75	60	50	41.7	30	25	20	16.7	15	12.5	10	8.3	7.5	
Applicable gear head	MZ9G3B to MZ9G200B (ball bearing / hinge not attached)	50 Hz	0.98	1.18	1.57	1.96	2.35	2.94	3.14	3.92	4.70	5.59	6.27	7.55	9.11	11.0	15.2	17.8							19.6	(173)
			(8.7)	(10.4)	(13.9)	(17.3)	(20.8)	(26.0)	(27.8)	(34.7)	(41.6)	(49.5)	(55.5)	(66.8)	(80.6)	(97.4)	(135)	(158)								
Applicable gear head	MY9G3B to MY9G200B (ball bearing / hinge attached)	60 Hz	0.78	0.98	1.37	1.57	1.96	2.35	2.65	3.33	3.92	4.70	5.29	6.47	7.55	9.11	12.6	15.2							19.6	(173)
			(6.9)	(8.7)	(12.1)	(13.9)	(17.3)	(20.8)	(23.5)	(29.5)	(34.7)	(41.6)	(46.8)	(57.3)	(66.8)	(80.6)	(112)	(135)								
Rotational direction	Same as motor rotational direction										Reverse to motor rotational direction										Same as motor rotational direction					

Permissible torque at output shaft of gear head using decimal gear head

* For external dimensions of the decimal gear head, refer to page B-448.

Applicable gear head	Reduction ratio	Speed (r/min)											
		250	300	360	500	600	750	900	1000	1200	1500	1800	
Bearing	MZ9G10XB	50 Hz	6	5	4.2	3	2.5	2	1.7	1.5	1.3	1	0.8
		60 Hz	7.2	6	5	3.6	3	2.4	2	1.8	1.5	1.2	1
Permissible torque	N-m (lb-in)	19.6	19.6	19.6	19.6	19.6	19.6	19.6	19.6	19.6	19.6	19.6	19.6
		(173)	(173)	(173)	(173)	(173)	(173)	(173)	(173)	(173)	(173)	(173)	(173)
Rotational direction	Reverse to motor rotational direction						Same as motor rotational direction						

Connection diagram

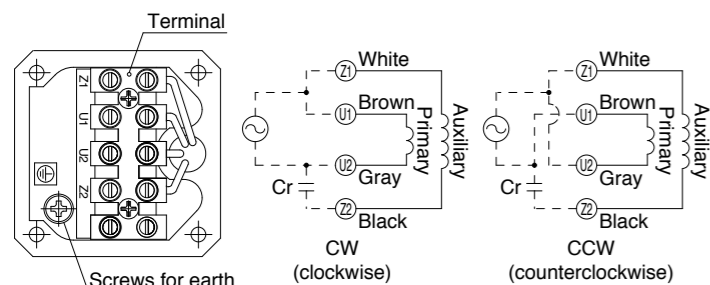

Speed-torque characteristics

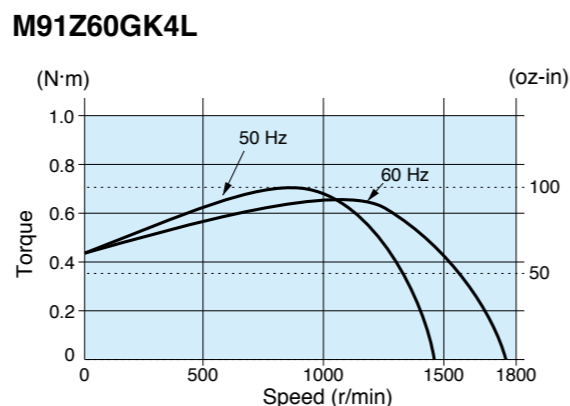

* Please read your User's manual carefully so that you will understand the operation and safety precautions before attempting to operate the system.

Features B-2 System configuration B-3 Coding system B-3 Model list B-4

Motor (dimensions)

Scale: 1/4, Unit: mm (inch)

M91Z60GK4L 4P 60 W 100 V (with fan)
M91Z60GK4Y 4P 60 W 200 V (with fan)

Mass 3.0 kg 6.61 lb
Helical gear
Module 0.6
Number of teeth 9

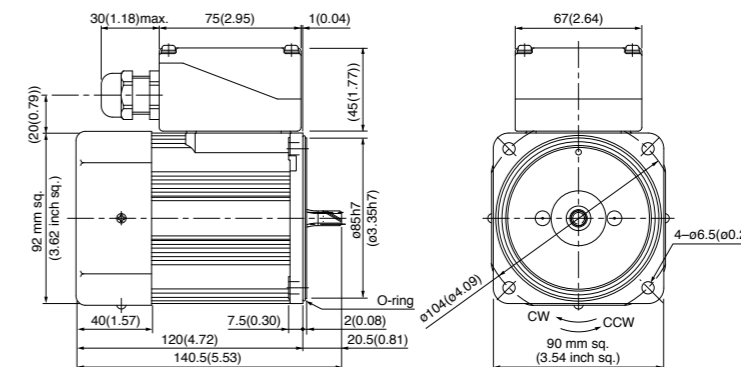

* Diameter of applicable cable to be $\phi 8(\phi 0.31)$ to $\phi 12(\phi 0.47)$.

Capacitor (dimensions) [attachment]

Unit: mm (inch)

Capacitor cap (dimensions) [option]

Unit: mm (inch)

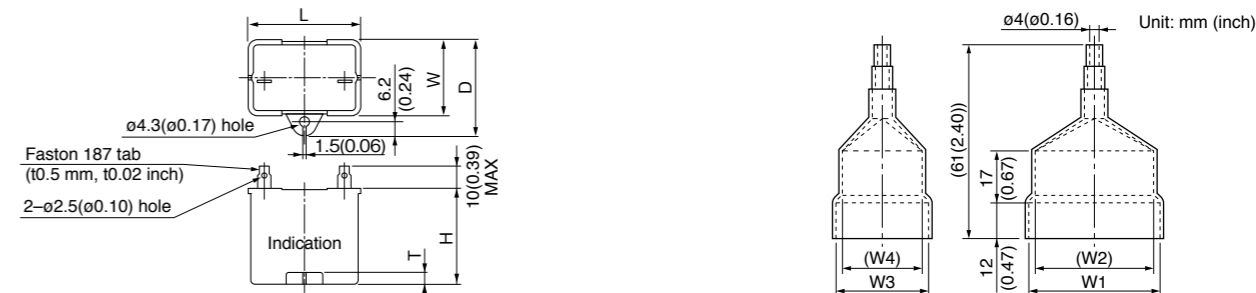

Capacitor dimension list

Unit: upper (mm) / lower (inch)

Model number of motor	Model number of capacitor (attachment)	L	W	D	H	T	Capacitor cap (option)	W1	W2	W3	W4
M91Z60GK4L	M0PC15M20	39.5 (1.56)	26.7 (1.05)	37 (1.46)	41 (1.61)	4 (0.16)	M0PC3926	39.5 (1.56)	37.5 (1.48)	26 (1.02)	25 (0.98)
M91Z60GK4Y	M0PC3.8M40	50 (1.97)	26.7 (1.05)	37.5 (1.48)	38 (1.50)	4 (0.16)	M0PC5026	50 (1.97)	48 (1.89)	26 (1.02)	22 (0.87)

* Capacitors (single item) can also be purchased.

Gear head (dimensions)

Scale: 1/4, Unit: mm (inch)

MZ9G□B (ball bearing / hinge not attached)
Mass 1.4 kg (3.09 lb)

MY9G□B (ball bearing / hinge attached)
Mass 1.4 kg (3.09 lb)

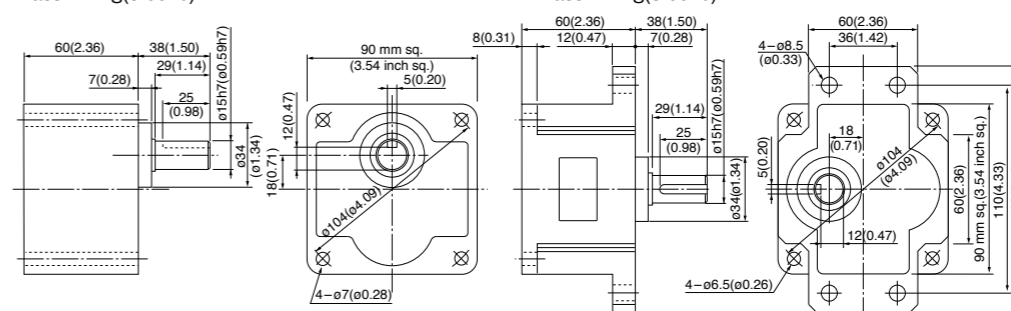

Note) MZ / MY is available for a gear head of either type.

(Note) Because the dimensions may be subject to change, also check the determinate dimensions if the gear head is to be used for design.

Gear head combination B-60 Round shaft motor B-62 Decimal gear head B-448 Gear head -inch (U.S.A.) B-449 Controls C-4 Option D-2

Key and keyway (dimensions) [attachment]

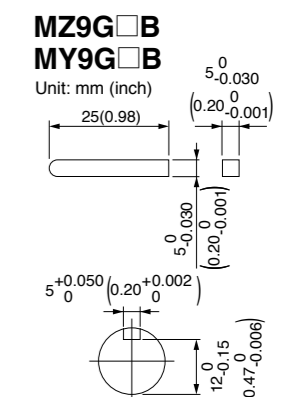

Induction motor (sealed connector)

US CE CCC **90 mm (3.54 inch) sq. 60 W**

Specifications

Size	Motor model No.	Number of pole (P)	Output (W)	Voltage (V)	Frequency (Hz)	Rating (min)	Rating				Starting current (A)	Starting torque N-m (oz-in)	Capacitor (μF) (rated voltage)
							Input (W)	Current (A)	Speed (r/min)	Torque N-m (oz-in)			
90 mm sq.	M91Z60GK4LG M91Z60GK4LGA	4	60	100	50	Cont.	119	1.3	1250	0.46 (65.1)	2.4	0.44 (62.3)	20 (250 V)
					60		112	1.2	1575	0.36 (51.0)	2.3	0.44 (62.3)	
	M91Z60GK4DG M91Z60GK4DGA	4	60	110	60	Cont.	120	1.1	1625	0.35 (49.6)	2.5	0.49 (69.4)	18 (250 V)
					115		127	1.2	1625	0.35 (49.6)	2.6	0.53 (75.1)	
	M91Z60GK4YG M91Z60GK4YGA	4	60	200	50	Cont.	114	0.57	1225	0.47 (66.6)	1.0	0.44 (62.3)	5 (450 V)
					60		122	0.62	1550	0.37 (52.4)	1.0	0.44 (62.3)	
	M91Z60GK4GG M91Z60GK4GGA	4	60	220	50	Cont.	121	0.58	1275	0.45 (63.7)	1.1	0.49 (69.4)	4.5 (450 V)
					60		120	0.55	1600	0.36 (51.0)	1.1	0.49 (69.4)	
					50		129	0.61	1300	0.44 (62.3)	1.1	0.53 (75.1)	
					60		126	0.55	1625	0.35 (49.6)	1.1	0.53 (75.1)	
	M91Z60GK4GGB M91Z60GK4GGC	4	60	230	50	Cont.	106	0.48	1350	0.42 (4.3)	1.0	0.40 (4.0)	4.5 (450 V)
					60		123	0.59	1650	0.34 (3.5)	0.97	0.40 (4.0)	
50					112		0.49	1375	0.42 (4.3)	1.1	0.43 (4.4)		
60					128		0.59	1675	0.34 (3.5)	1.0	0.43 (4.4)		

The specifications and wire connections of the round shaft motor are the same as those of the pinion shaft type. For the dimensional outline drawing, refer to page B-62.
The models with a motor model number to which "A" is suffixed are not equipped with a capacitor cap.
The models with a motor model number to which "A" is suffixed are not sold or available in Japan.

Permissible torque at output shaft of gear head

* The speed shown below is a calculated value based on the synchronous rotational speed. Depending on the load, the speed is less than the indicated value by 2% to 20%.

Unit of permissible torque: upper (N-m) / lower (lb-in)

Reduction ratio	3	3.6	5	6	7.5	9	10	12.5	15	18	20	25	30	36	50	60	75	90	100	120	150	180	200					
Speed (r/min)	50 Hz	500	416.7	300	250	200	166.7	150	120	100	83.3	75	60	50	41.7	30	25	20	16.7	15	12.5	10	8.3	7.5				
Applicable gear head	50 Hz	0.98	1.18	1.57	1.96	2.35	2.94	3.14	3.92	4.70	5.59	6.27	7.55	9.11	11.0	15.2	17.8							19.6				
	60 Hz	0.78	0.98	1.37	1.57	1.96	2.35	2.65	3.33	3.92	4.70	5.29	6.47	7.55	9.11	12.6	15.2							19.6				
Rotational direction	Same as motor rotational direction										Reverse to motor rotational direction										Same as motor rotational direction							

Permissible torque at output shaft of gear head using decimal gear head

* For external dimensions of the decimal gear head, refer to page B-448.

Applicable gear head	Reduction ratio	250	300	360	500	600	750	900	1000	1200	1500	1800		
Bearing	Decimal gear head	Speed (r/min)	50 Hz	6	5	4.2	3	2.5	2	1.7	1.5	1.3	1	0.8
	60 Hz	7.2	6	5	3.6	3	2.4	2	1.8	1.5	1.2	1		
MZ9G□B (ball bearing / hinge not attached) MY9G□B (ball bearing / hinge attached)	MZ9G10XB	Permissible torque	N-m	19.6	19.6	19.6	19.6	19.6	19.6	19.6	19.6	19.6	19.6	19.6
			(lb-in)	(173)	(173)	(173)	(173)	(173)	(173)	(173)	(173)	(173)	(173)	(173)
Rotational direction	Reverse to motor rotational direction										Same as motor rotational direction			

Connection diagram

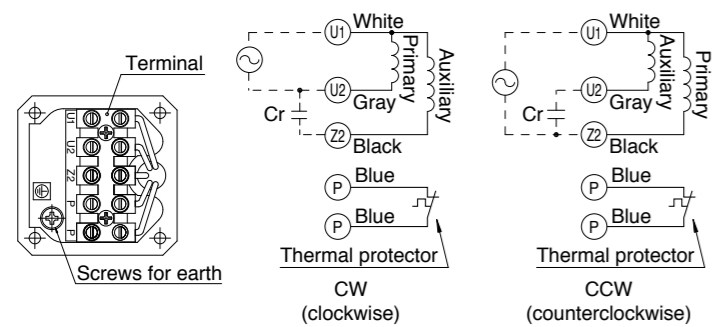

(Refer to page A-60 for connection of thermal protector.)

Speed-torque characteristics

M91Z60GK4LG(A)

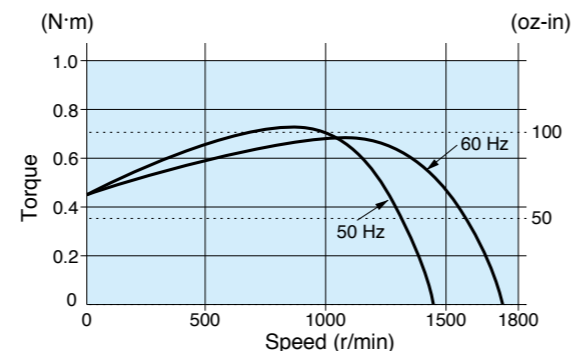

* Please read your User's manual carefully so that you will understand the operation and safety precautions before attempting to operate the system.

Features B-2 System configuration B-3 Coding system B-3 Model list B-4

Motor (dimensions)

Scale: 1/4, Unit: mm (inch)

Model No.	4P	6P	W	100 V	(with fan)
M91Z60GK4LG(A)	4P	60 W	110 V / 115 V	(with fan)	
M91Z60GK4YG(A)	4P	60 W	200 V	(with fan)	
M91Z60GK4GG(A)	4P	60 W	220 V / 230 V	(with fan)	
M91Z60GK4GGB	4P	60 W	220 V / 230 V	(with fan)	
M91Z60GK4GGC	4P	60 W	220 V / 230 V	(with fan)	

Mass	Helical gear	Module	Number of teeth
3.0 kg 6.61 lb		0.6	9

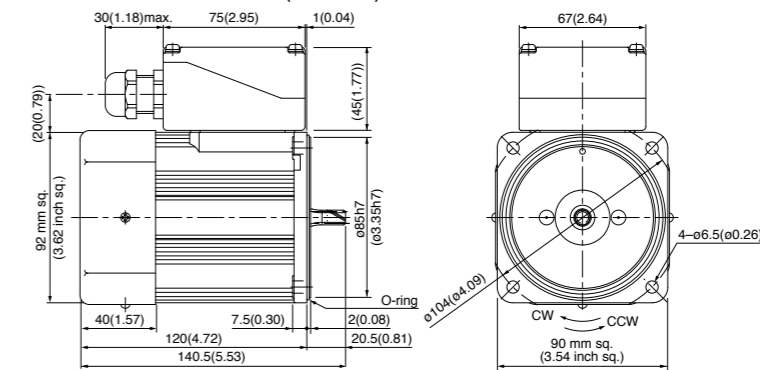

* Diameter of applicable cable to be $\varnothing 8(\varnothing 0.31)$ to $\varnothing 12(\varnothing 0.47)$.

Capacitor (dimensions) [attachment]

Unit: mm (inch)

Capacitor cap (dimensions) [attachment]

Unit: mm (inch)

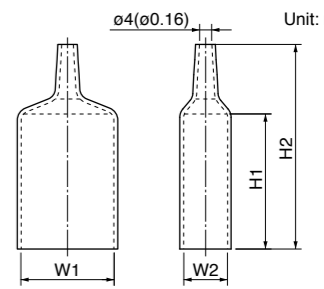
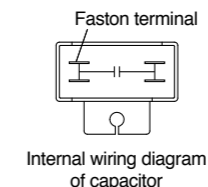
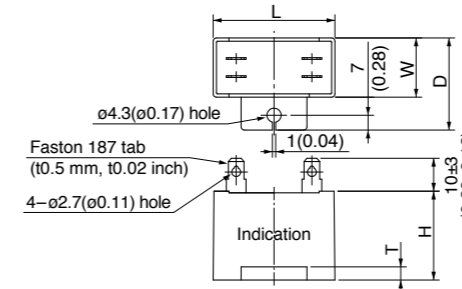

Capacitor dimension list Unit: upper (mm) / lower (inch)

Model number of motor	Model number of capacitor (attachment)	L	W	D	H	T	Capacitor cap (attachment)	W1	W2	H1	H2
M91Z60GK4LG(A)	M0PC20M25G	58 (2.28)	29 (1.14)	44 (1.73)	41 (1.61)	4 (0.16)	M0PC5829G	58 (2.28)	29 (1.14)	55 (2.17)	78 (3.07)
M91Z60GK4DG(A)	M0PC18M25G	58 (2.28)	29 (1.14)	44 (1.73)	41 (1.61)	4 (0.16)	M0PC5829G	58 (2.28)	29 (1.14)	55 (2.17)	78 (3.07)
M91Z60GK4YG(A)	M0PC5M45G	58 (2.28)	29 (1.14)	44 (1.73)	41 (1.61)	4 (0.16)	M0PC5829G	58 (2.28)	29 (1.14)	55 (2.17)	78 (3.07)
M91Z60GK4GG(A)	M0PC4.5M45G	58 (2.28)	23.5 (0.93)	38.5 (1.52)	37 (1.46)	4 (0.16)	M0PC5823G	58 (2.28)	23.5 (0.93)	55 (2.17)	78 (3.07)
M91Z60GK4GGB											
M91Z60GK4GGC											

The models with a motor model number to which "A" or "B" is suffixed are not equipped with a capacitor cap.
* Capacitors (single item), capacitor cap (single item) can also be purchased.

Gear head (dimensions)

Scale: 1/4, Unit: mm (inch)

MZ9G□B (ball bearing / hinge not attached)
Mass 1.4 kg (3.09 lb)

MY9G□B (ball bearing / hinge attached)
Mass 1.4 kg (3.09 lb)

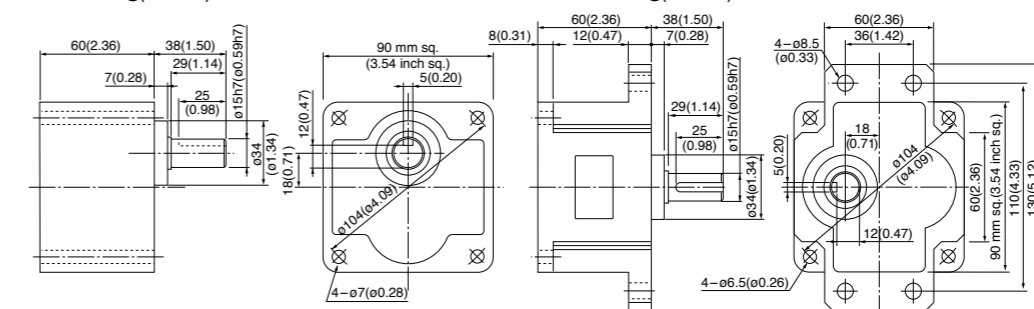

Note) MZ / MY is available for a gear head of either type.

(Note) Because the dimensions may be subject to change, also check the determinate dimensions if the gear head is to be used for design.

Gear head combination B-60 Round shaft motor B-62 Decimal gear head B-448 Gear head -inch (U.S.A.) B-449 Controls C-4 Option D-2

Induction motor (sealed connector)

90 mm (3.54 inch) sq. 90 W

Specifications

Size	Motor model No.	Number of pole (P)	Output (W)	Voltage (V)	Frequency (Hz)	Rating (min)	Rating				Starting current (A)	Starting torque N-m (oz-in)	Capacitor (μF) (rated voltage)
							Input (W)	Current (A)	Speed (r/min)	Torque N-m (oz-in)			
90mm sq.	M91Z90GK4L	4	90	100	50	Cont.	153	1.6	1325	0.65 (92.0)	3.3	0.47 (66.6)	25 (200 V)
							160	1.6	1625	0.53 (75.1)	3.0	0.47 (66.6)	
	M91Z90GK4Y	4	90	200	50	Cont.	150	0.75	1325	0.62 (87.8)	1.7	0.47 (66.6)	5.8 (400 V)
							160	0.80	1650	0.51 (72.2)	1.5	0.47 (66.6)	

* The specifications and wire connections of the round shaft motor are the same as those of the pinion shaft type. For the dimensional outline drawing, refer to page B-62.

Permissible torque at output shaft of gear head

* The speed shown below is a calculated value based on the synchronous rotational speed. Depending on the load, the speed is less than the indicated value by 2% to 20%.

Unit of permissible torque: upper (N·m) / lower (lb-in)

Reduction ratio	Unit of permissible torque: upper (N·m) / lower (lb-in)																							
	3	3.6	5	6	7.5	9	10	12.5	15	18	20	25	30	36	50	60	75	90	100	120	150	180	200	
Speed (r/min)	50 Hz	500	416.7	300	250	200	166.7	150	120	100	83.3	75	60	50	41.7	30	25	20	16.7	15	12.5	10	8.3	7.5
	60 Hz	600	500	360	300	240	200	180	144	120	100	90	72	60	50	36	30	24	20	18	15	12	10	9
Applicable gear head	MZ9G3B to MZ9G200B (ball bearing / hinge not attached)	50 Hz	1.37 (12.1)	1.67 (14.8)	2.25 (19.9)	2.74 (24.3)	3.43 (30.4)	4.12 (36.5)	4.51 (39.9)	5.68 (50.3)	6.76 (59.8)	8.04 (71.2)	9.02 (79.8)	10.9 (96.5)	13.0 (115)	15.7 (139)	19.6 (173)							19.6 (173)
	MY9G3B to MY9G200B (ball bearing / hinge attached)	60 Hz	1.18 (10.4)	1.37 (12.1)	1.86 (16.5)	2.25 (19.9)	2.84 (25.1)	3.43 (30.4)	3.72 (32.9)	4.70 (41.6)	5.68 (50.3)	6.76 (59.8)	7.55 (66.8)	9.21 (81.5)	10.9 (96.5)	13.0 (115)	18.3 (162)							19.6 (173)
Rotational direction	Same as motor rotational direction						Reverse to motor rotational direction						Same as motor rotational direction											

Permissible torque at output shaft of gear head using decimal gear head

* For external dimensions of the decimal gear head, refer to page B-448.

Applicable gear head	Reduction ratio	Permissible torque											
		250	300	360	500	600	750	900	1000	1200	1500	1800	
Bearing	Speed (r/min)	50 Hz	6	5	4.2	3	2.5	2	1.7	1.5	1.3	1	0.8
		60 Hz	7.2	6	5	3.6	3	2.4	2	1.8	1.5	1.2	1
MZ9G□B (ball bearing / hinge not attached) MY9G□B (ball bearing / hinge attached)	MZ9G10XB	Permissible torque	19.6 (173)	19.6 (173)	19.6 (173)	19.6 (173)	19.6 (173)	19.6 (173)	19.6 (173)	19.6 (173)	19.6 (173)	19.6 (173)	19.6 (173)
		Rotational direction	Reverse to motor rotational direction						Same as motor rotational direction				

Motor (dimensions)

Scale: 1/4, Unit: mm (inch)

M91Z90GK4L 4P 90 W 100 V (with fan)
M91Z90GK4Y 4P 90 W 200 V (with fan)

Mass 3.3 kg 7.28 lb
Helical gear
Module 0.6
Number of teeth 9

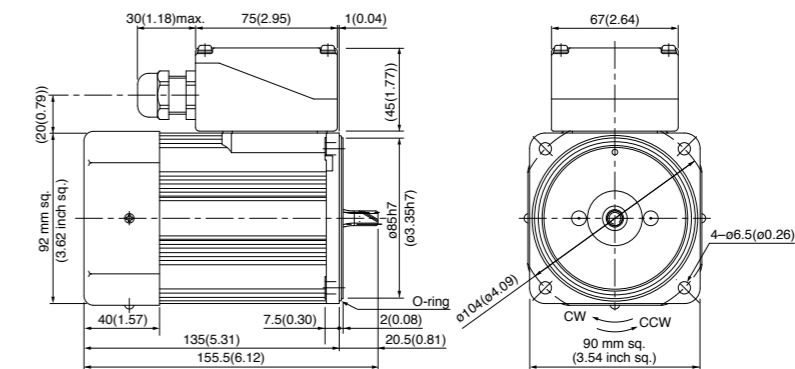

* Diameter of applicable cable to be ø8(ø0.31) to ø12(ø0.47).

Capacitor (dimensions) [attachment]

Unit: mm (inch)

Capacitor cap (dimensions) [option]

Unit: mm (inch)



Capacitor dimension list

Unit: upper (mm) / lower (inch)

Model number of motor	Model number of capacitor (attachment)	L	W	D	H	T	Capacitor cap (option)	W1	W2	W3	W4
M91Z90GK4L	M0PC25M20	50.2 (1.98)	31	41 (1.61)	42 (1.65)	5 (0.20)	M0PC5032	50 (1.97)	48 (1.89)	32.5 (1.28)	29.5 (1.16)
M91Z90GK4Y	M0PC5.8M40	50 (1.97)	30.5 (1.20)	41 (1.61)	41.5 (1.63)	4 (0.16)	M0PC5032	50 (1.97)	48 (1.89)	32.5 (1.28)	29.5 (1.16)

* Capacitors (single item) can also be purchased.

Connection diagram

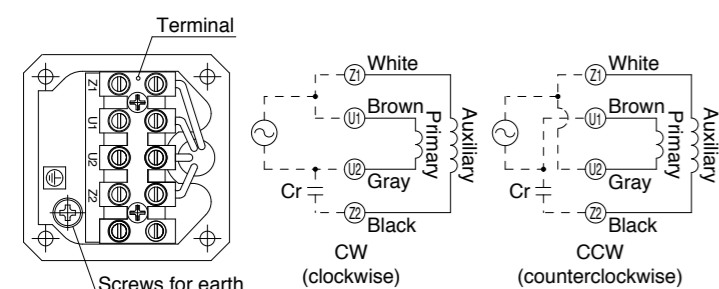

Speed-torque characteristics

M91Z90GK4L

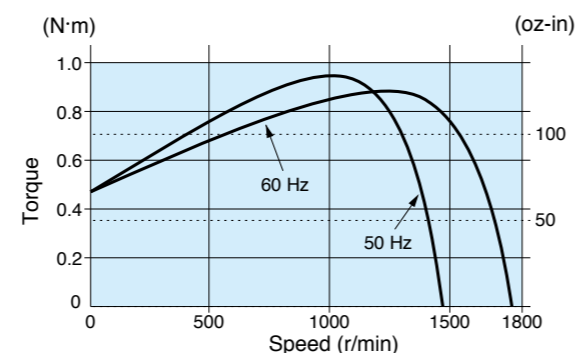

* Please read your User's manual carefully so that you will understand the operation and safety precautions before attempting to operate the system.

Features B-2 System configuration B-3 Coding system B-3 Model list B-4

Gear head (dimensions)

Scale: 1/4, Unit: mm (inch)

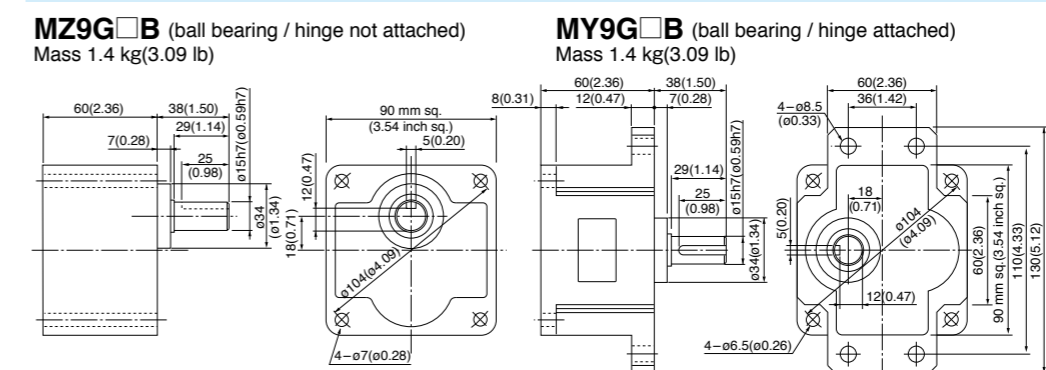

Note) MZ / MY is available for a gear head of either type.

(Note) Because the dimensions may be subject to change, also check the determinate dimensions if the gear head is to be used for design.

Gear head combination B-60 Round shaft motor B-62 Decimal gear head B-448 Gear head -inch (U.S.A.) B-449 Controls C-4 Option D-2

Key and keyway (dimensions) [attachment]

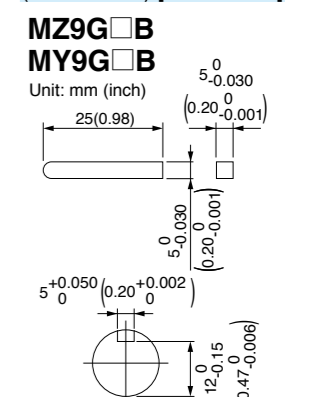

Induction motor (sealed connector)

c **UL** US **CE** **CCC** **90 mm (3.54 inch) sq.** **90 W**

Specifications

Size	Motor model No.	Number of pole (P)	Output (W)	Voltage (V)	Frequency (Hz)	Rating (min)	Rating				Starting current (A)	Starting torque N-m (oz-in)	Capacitor (μF) (rated voltage)
							Input (W)	Current (A)	Speed (r/min)	Torque N-m (oz-in)			
90 mm sq.	M91Z90GK4LG	4	90	100	50	Cont.	172	1.8	1250	0.69(97.7)	3.0	0.65(92.0)	30 (250 V)
	M91Z90GK4LGA						177	1.8	1575	0.55(77.9)	2.8	0.65(92.0)	
	M91Z90GK4DG	4	90	110	60	Cont.	168	1.6	1600	0.54(76.5)	3.0	0.65(92.0)	25 (250 V)
	M91Z90GK4DGA						176	1.6	1600	0.54(76.5)	3.1	0.72(102)	
	M91Z90GK4YG	4	90	200	50	Cont.	170	0.85	1225	0.70(99.1)	1.4	0.65(92.0)	7.5 (450 V)
	M91Z90GK4YGA						188	0.97	1550	0.55(77.9)	1.4	0.65(92.0)	
	M91Z90GK4GG M91Z90GK4GGA	4	90	220	60	Cont.	176	0.85	1225	0.70(99.1)	1.5	0.63(89.2)	6 (450 V)
							167	0.76	1575	0.55(77.9)	1.4	0.65(92.0)	
							185	0.89	1250	0.69(97.7)	1.5	0.68(96.3)	
							173	0.76	1600	0.54(76.5)	1.5	0.72(102)	
							153	0.70	1325	0.65(92.0)	1.4	0.55(77.9)	
							169	0.81	1625	0.53(75.1)	1.3	0.56(79.3)	
M91Z90GK4GGB M91Z90GK4GGC	4	90	230	50	Cont.	159	0.70	1350	0.64(90.6)	1.5	0.61(86.4)	6 (450 V)	
						176	0.81	1650	0.52(73.6)	1.4	0.63(89.2)		

The specifications and wire connections of the round shaft motor are the same as those of the pinion shaft type. For the dimensional outline drawing, refer to page B-62.
 The models with a motor model number to which "A" is suffixed are not equipped with a capacitor cap.
 The models with a motor model number to which "A" is suffixed are not sold or available in Japan.

Permissible torque at output shaft of gear head

* The speed shown below is a calculated value based on the synchronous rotational speed. Depending on the load, the speed is less than the indicated value by 2% to 20%.

Unit of permissible torque: upper (N·m) / lower (lb-in)

Reduction ratio	Unit of permissible torque: upper (N·m) / lower (lb-in)																							
	3	3.6	5	6	7.5	9	10	12.5	15	18	20	25	30	36	50	60	75	90	100	120	150	180	200	
Speed (r/min)	50 Hz	500	416.7	300	250	200	166.7	150	120	100	83.3	75	60	50	41.7	30	25	20	16.7	15	12.5	10	8.3	7.5
	60 Hz	600	500	360	300	240	200	180	144	120	100	90	72	60	50	36	30	24	20	18	15	12	10	9
Applicable gear head	MZ9G3B to MZ9G200B (ball bearing / hinge not attached)	50 Hz	1.37	1.67	2.25	2.74	3.43	4.12	4.51	5.68	6.76	8.04	9.02	10.9	13.0	15.7	19.6						19.6	(173)
	MY9G3B to MY9G200B (ball bearing / hinge attached)	60 Hz	1.18	1.37	1.86	2.25	2.84	3.43	3.72	4.70	5.68	6.76	7.55	9.21	10.9	13.0	18.3						19.6	(173)
Rotational direction		Same as motor rotational direction					Reverse to motor rotational direction					Same as motor rotational direction												

Permissible torque at output shaft of gear head using decimal gear head

* For external dimensions of the decimal gear head, refer to page B-448.

Applicable gear head		Reduction ratio	250	300	360	500	600	750	900	1000	1200	1500	1800	
Bearing	Decimal gear head	Speed (r/min)	50 Hz	6	5	4.2	3	2.5	2	1.7	1.5	1.3	1	0.8
		60 Hz	7.2	6	5	3.6	3	2.4	2	1.8	1.5	1.2	1	
MZ9G□B (ball bearing / hinge not attached)	MZ9G10XB	Permissible torque	N-m	19.6	19.6	19.6	19.6	19.6	19.6	19.6	19.6	19.6	19.6	19.6
		(lb-in)	(173)	(173)	(173)	(173)	(173)	(173)	(173)	(173)	(173)	(173)	(173)	(173)
MY9G□B (ball bearing / hinge attached)		Rotational direction	Reverse to motor rotational direction					Same as motor rotational direction						

Connection diagram

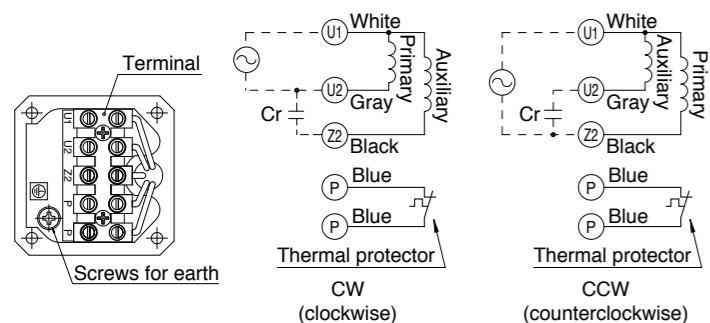

(Refer to page A-60 for connection of thermal protector.)

Speed-torque characteristics

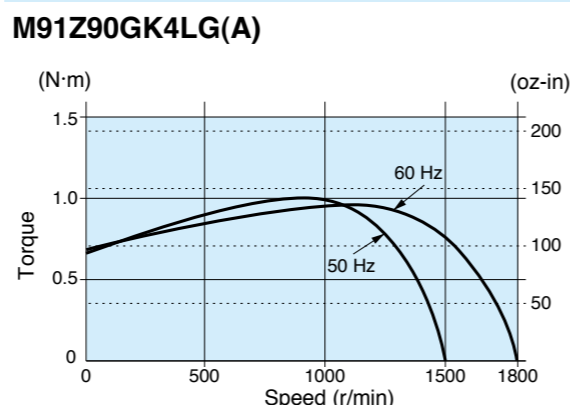

Motor (dimensions)

Scale: 1/4, Unit: mm (inch)

M91Z90GK4LG(A) 4P 90 W 100 V (with fan)
 M91Z90GK4DG(A) 4P 90 W 110 V / 115 V (with fan)
 M91Z90GK4YG(A) 4P 90 W 200 V (with fan)
 M91Z90GK4GG(A) 4P 90 W 220 V / 230 V (with fan)
 M91Z90GK4GGB 4P 90 W 220 V / 230 V (with fan)
 M91Z90GK4GGC 4P 90 W 220 V / 230 V (with fan)

Mass **3.3 kg** **7.28 lb**
 Helical gear
 Module **0.6**
 Number of teeth **9**

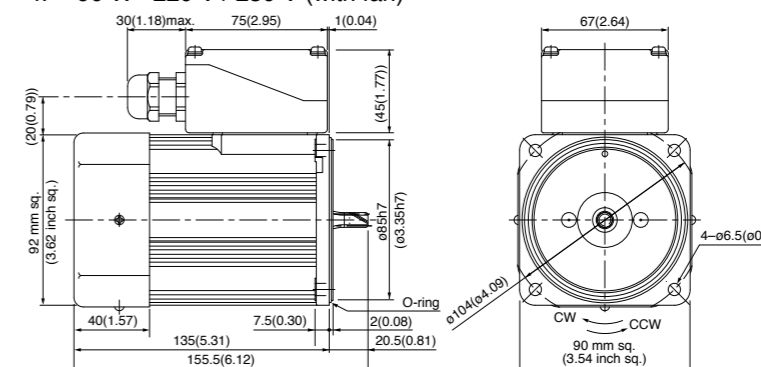

* Diameter of applicable cabtyre cable to be ø8(ø0.31) to ø12(ø0.47).

Capacitor (dimensions) [attachment]

Unit: mm (inch)

Capacitor cap (dimensions) [attachment]

Unit: mm (inch)

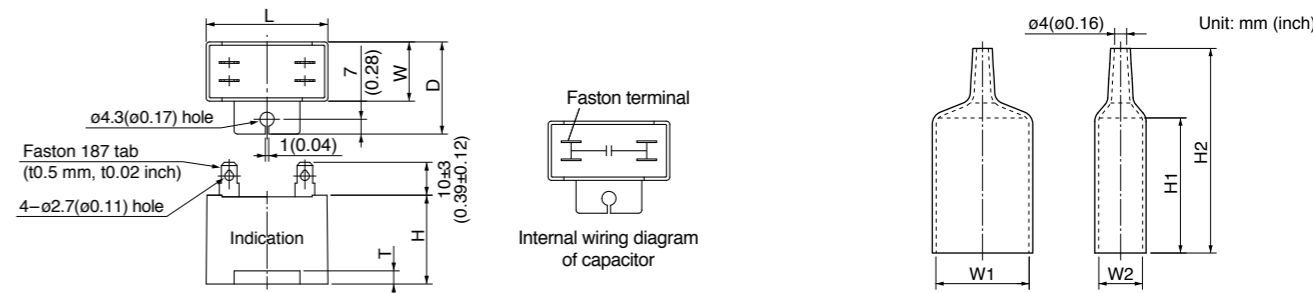

Capacitor dimension list Unit: upper (mm) / lower (inch)

Model number of motor	Model number of capacitor (attachment)	L	W	D	H	T	Capacitor cap (attachment)	W1	W2	H1	H2
M91Z90GK4LG(A)	M0PC30M25G	58 (2.28)	35 (1.38)	50 (1.97)	50 (1.97)	4 (0.16)	M0PC5835G	58 (2.28)	35 (1.38)	55 (2.17)	78 (3.07)
M91Z90GK4DG(A)	M0PC25M25G	58 (2.28)	35 (1.38)	50 (1.97)	50 (1.97)	4 (0.16)	M0PC5835G	58 (2.28)	35 (1.38)	55 (2.17)	78 (3.07)
M91Z90GK4YG(A)	M0PC7.5M45G	58 (2.28)	35 (1.38)	50 (1.97)	50 (1.97)	4 (0.16)	M0PC5835G	58 (2.28)	35 (1.38)	55 (2.17)	78 (3.07)
M91Z90GK4GG(A)	M0PC6M45G	58 (2.28)	29 (1.14)	44 (1.73)	41 (1.61)	4 (0.16)	M0PC5829G	58 (2.28)	29 (1.14)	55 (2.17)	78 (3.07)
M91Z90GK4GGB											
M91Z90GK4GGC											

The models with a motor model number to which "A" or "B" is suffixed are not equipped with a capacitor cap.
 * Capacitors (single item), capacitor cap (single item) can also be purchased.

Gear head (dimensions)

Scale: 1/4, Unit: mm (inch)

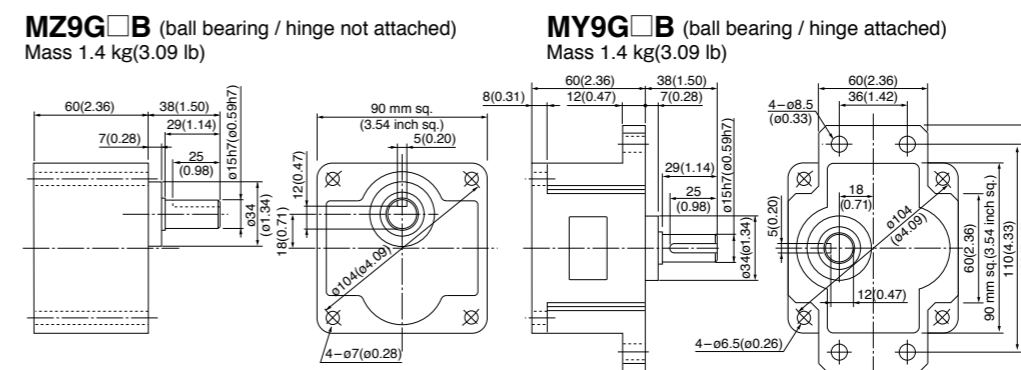

Note) MZ / MY is available for a gear head of either type.

Key and keyway (dimensions) [attachment]

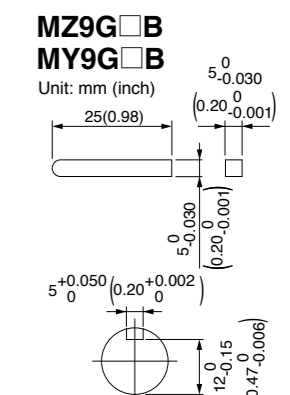

(Note) Because the dimensions may be subject to change, also check the determinate dimensions if the gear head is to be used for design.

* Please read your User's manual carefully so that you will understand the operation and safety precautions before attempting to operate the system.

Features B-2 System configuration B-3 Coding system B-3 Model list B-4

Gear head combination B-60 Round shaft motor B-62 Decimal gear head B-448 Gear head -inch (U.S.A.) B-449 Controls C-4 Option D-2

Induction motor (leadwire)

Gear head combination dimensions

Scale: 1/4, Unit: mm (inch)

* Gear head is sold separately.

42 mm sq. (1.65 inch sq.) 3 W

M41A3G2L + M4GA□F

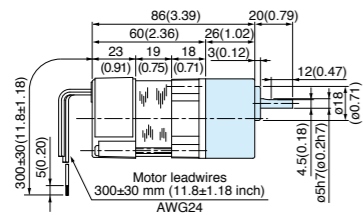

42 mm sq. (1.65 inch sq.) 1 W

M41A1G4L + M4GA□F

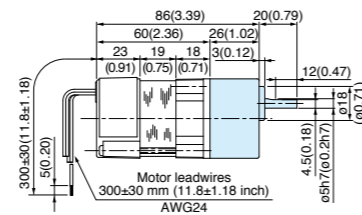

60 mm sq. (2.36 inch sq.) 3 W

M61X3G4L + MX6G□BA(MA) / MX6G□B(M)

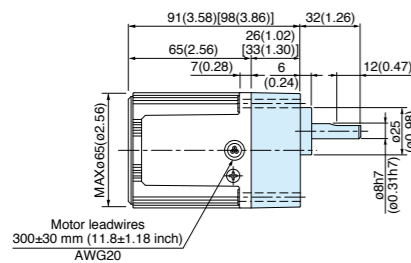

* Figures in [] represent the dimensions of MX6G□B (M) (1/30 or larger reduction ratio).

The model number of the gear head with a reduction ratio of 1/25 or smaller is MX6G□BA (MA).

70 mm sq. (2.76 inch sq.) 10 W

M71X10G4L + MX7G□BA(MA) / MX7G□B(M)
M71X10G4Y + MX7G□BA(MA) / MX7G□B(M)

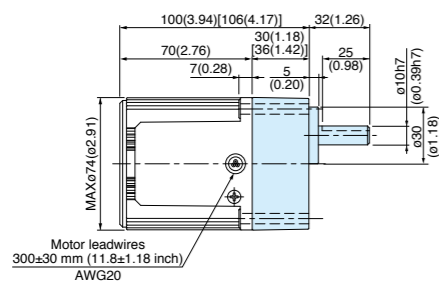

* Figures in [] represent the dimensions of MX7G□B (M) (1/30 or larger reduction ratio).

The model number of the gear head with a reduction ratio of 1/25 or smaller is MX7G□BA (MA).

60 mm sq. (2.36 inch sq.) 6 W

M61X6G4L + MX6G□BA(MA) / MX6G□B(M)
M61X6G4Y + MX6G□BA(MA) / MX6G□B(M)
M61X6G4LG(A) + MX6G□BA(MA) / MX6G□B(M)
M61X6G4DG(A) + MX6G□BA(MA) / MX6G□B(M)
M61X6G4YG(A) + MX6G□BA(MA) / MX6G□B(M)
M61X6G4GG(A) + MX6G□BA(MA) / MX6G□B(M)

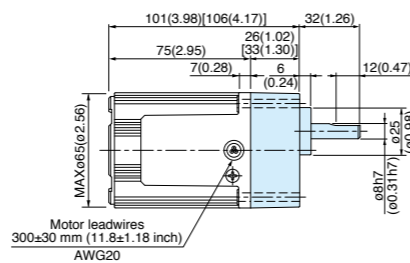

* Figures in [] represent the dimensions of MX6G□B (M) (1/30 or larger reduction ratio).

The model number of the gear head with a reduction ratio of 1/25 or smaller is MX6G□BA (MA).

70 mm sq. (2.76 inch sq.) 15 W

M71X15G4L + MX7G□BA(MA) / MX7G□B(M)
M71X15G4Y + MX7G□BA(MA) / MX7G□B(M)
M71X15G4LG(A) + MX7G□BA(MA) / MX7G□B(M)
M71X15G4DG(A) + MX7G□BA(MA) / MX7G□B(M)
M71X15G4YG(A) + MX7G□BA(MA) / MX7G□B(M)
M71X15G4GG(A) + MX7G□BA(MA) / MX7G□B(M)

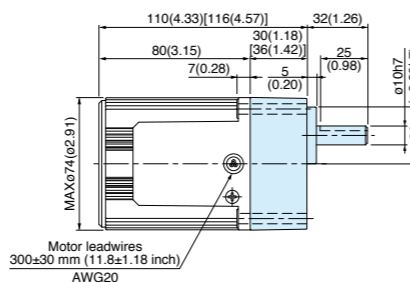

* Figures in [] represent the dimensions of MX7G□B (M) (1/30 or larger reduction ratio).

The model number of the gear head with a reduction ratio of 1/25 or smaller is MX7G□BA (MA).

80 mm sq. (3.15 inch sq.) 15 W

M81X15G4L + MX8G□B(M)
M81X15G4Y + MX8G□B(M)

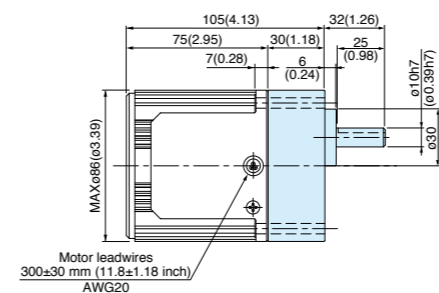

90 mm sq. (3.54 inch sq.) 40 W

M91X40G4L + MX9G□B(M)
M91X40G4Y + MX9G□B(M)
M91X40G4LG(A) + MX9G□B(M)
M91X40G4DG(A) + MX9G□B(M)
M91X40G4YG(A) + MX9G□B(M)
M91X40G4GG(A) + MX9G□B(M)

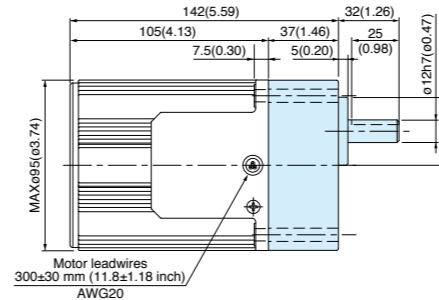

90 mm sq. (3.54 inch sq.) 90 W

M91Z90G4L + MY9G□B (MZ9G□B)
M91Z90G4Y + MY9G□B (MZ9G□B)
M91Z90G4LG(A) + MY9G□B (MZ9G□B)
M91Z90G4DG(A) + MY9G□B (MZ9G□B)
M91Z90G4YG(A) + MY9G□B (MZ9G□B)
M91Z90G4GG(A) + MY9G□B (MZ9G□B)
M91Z90G4GGB + MY9G□B (MZ9G□B)
M91Z90G4GGC + MY9G□B (MZ9G□B)

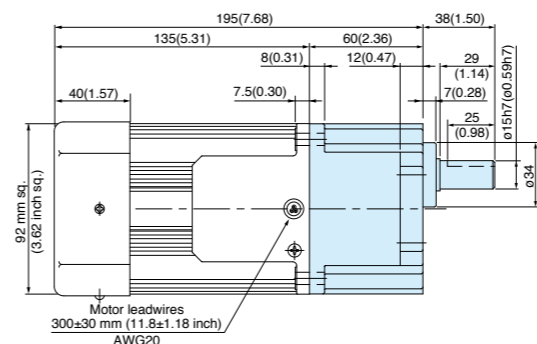

* Refer to page B-444 for high torque gear head.

(Note) Because the dimensions may be subject to change, also check the determinate dimensions if the gear head is to be used for design.

80 mm sq. (3.15 inch sq.) 25 W

M81X25G4L + MX8G□B(M)
M81X25G4Y + MX8G□B(M)
M81X25G4LG(A) + MX8G□B(M)
M81X25G4DG(A) + MX8G□B(M)
M81X25G4YG(A) + MX8G□B(M)
M81X25G4GG(A) + MX8G□B(M)

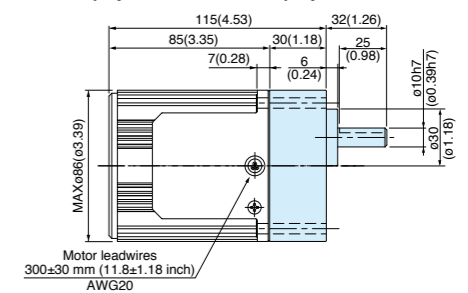

90 mm sq. (3.54 inch sq.) 60 W

M91Z60G4L + MZ9G□B (MY9G□B)
M91Z60G4Y + MZ9G□B (MY9G□B)
M91Z60G4LG(A) + MZ9G□B (MY9G□B)
M91Z60G4DG(A) + MZ9G□B (MY9G□B)
M91Z60G4YG(A) + MZ9G□B (MY9G□B)
M91Z60G4GG(A) + MZ9G□B (MY9G□B)
M91Z60G4GGB + MZ9G□B (MY9G□B)
M91Z60G4GGC + MZ9G□B (MY9G□B)

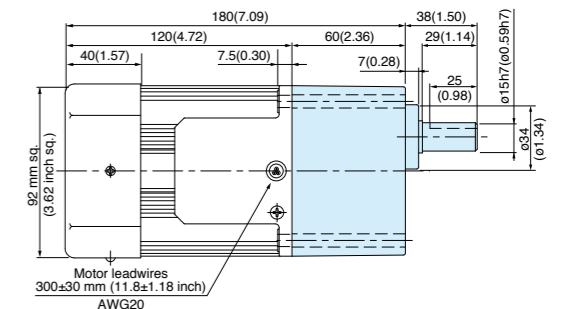

* Refer to page B-444 for high torque gear head.

* Please read your User's manual carefully so that you will understand the operation and safety precautions before attempting to operate the system.

Features B-2 System configuration B-3 Coding system B-3 Model list B-4

Specifications B-8 to B-57 Controls C-4 Option D-2

Induction motor (sealed connector) Gear head combination dimensions

Scale: 1/4, Unit: mm (inch)

* Gear head is sold separately.

80 mm sq. (3.15 inch sq.) 25 W

- M81X25GK4L + MX8G□B(M)
- M81X25GK4Y + MX8G□B(M)
- M81X25GK4LG(A) + MX8G□B(M)
- M81X25GK4DG(A) + MX8G□B(M)
- M81X25GK4YG(A) + MX8G□B(M)
- M81X25GK4GG(A) + MX8G□B(M)

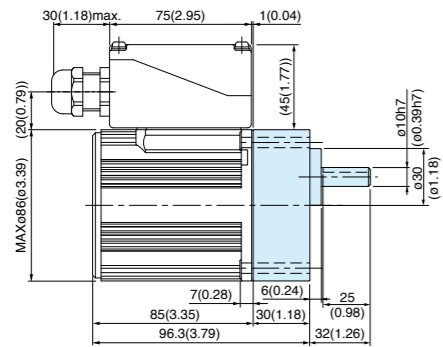

* Diameter of applicable cabtyre cable to be $\phi 8(\phi 0.31)$ to $\phi 12(\phi 0.47)$.

90 mm sq. (3.54 inch sq.) 40 W

- M91X40GK4L + MX9G□B(M)
- M91X40GK4Y + MX9G□B(M)
- M91X40GK4LG(A) + MX9G□B(M)
- M91X40GK4DG(A) + MX9G□B(M)
- M91X40GK4YG(A) + MX9G□B(M)
- M91X40GK4GG(A) + MX9G□B(M)

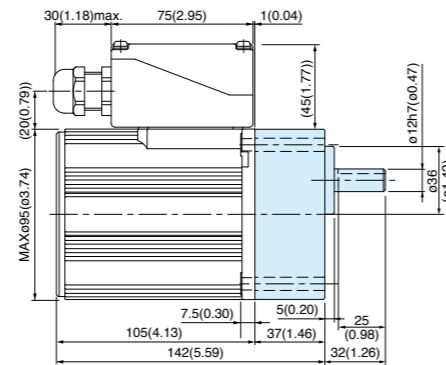

* Diameter of applicable cabtyre cable to be $\phi 8(\phi 0.31)$ to $\phi 12(\phi 0.47)$.

90 mm sq. (3.54 inch sq.) 60 W

- M91Z60GK4L + MZ9G□B (MY9G□B)
- M91Z60GK4Y + MZ9G□B (MY9G□B)
- M91Z60GK4LG(A) + MZ9G□B (MY9G□B)
- M91Z60GK4DG(A) + MZ9G□B (MY9G□B)
- M91Z60GK4YG(A) + MZ9G□B (MY9G□B)
- M91Z60GK4GG(A) + MZ9G□B (MY9G□B)
- M91Z60GK4GGB + MZ9G□B (MY9G□B)
- M91Z60GK4GGC + MZ9G□B (MY9G□B)

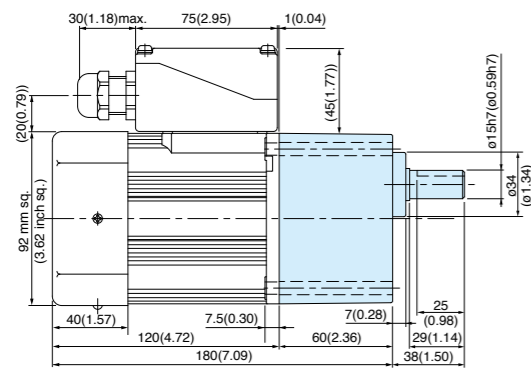

* Diameter of applicable cabtyre cable to be $\phi 8(\phi 0.31)$ to $\phi 12(\phi 0.47)$.

* Refer to page B-444 for high torque gear head.

90 mm sq. (3.54 inch sq.) 90 W

- M91Z90GK4L + MY9G□B (MZ9G□B)
- M91Z90GK4Y + MY9G□B (MZ9G□B)
- M91Z90GK4LG(A) + MY9G□B (MZ9G□B)
- M91Z90GK4DG(A) + MY9G□B (MZ9G□B)
- M91Z90GK4YG(A) + MY9G□B (MZ9G□B)
- M91Z90GK4GG(A) + MY9G□B (MZ9G□B)
- M91Z90GK4GGB + MY9G□B (MZ9G□B)
- M91Z90GK4GGC + MY9G□B (MZ9G□B)

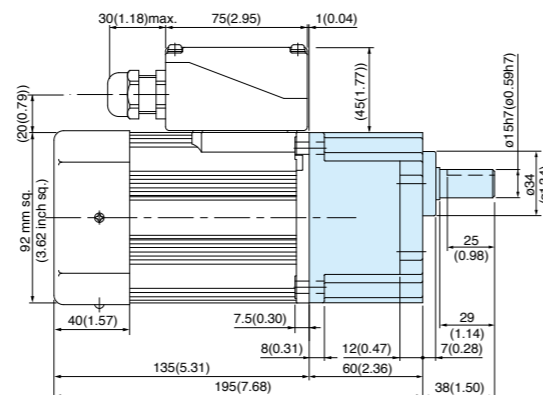

* Diameter of applicable cabtyre cable to be $\phi 8(\phi 0.31)$ to $\phi 12(\phi 0.47)$.

* Refer to page B-444 for high torque gear head.

* The models with a motor model number to which "A" or "B" is suffixed are not equipped with a capacitor cap.

* The models with a motor model number to which "A" or "B" is suffixed are not sold or available in Japan.

* Please read your User's manual carefully so that you will understand the operation and safety precautions before attempting to operate the system.

Features B-2 System configuration B-3 Coding system B-3 Model list B-4

Induction motor (4-pole round shaft / leadwire)

Dimensions
Scale: 1/4, Unit: mm (inch)

42 mm sq. (1.65 inch sq.) 1 W

Mass
0.3 kg (0.66 lb)

M41A1S4L

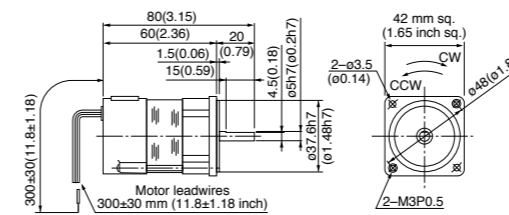

60 mm sq. (2.36 inch sq.) 6 W

Mass
0.67 kg (1.48 lb)

M61X6S4LS M61X6S4LG(A) M61X6S4YG(A)
M61X6S4YS M61X6S4DG(A) M61X6S4GG(A)

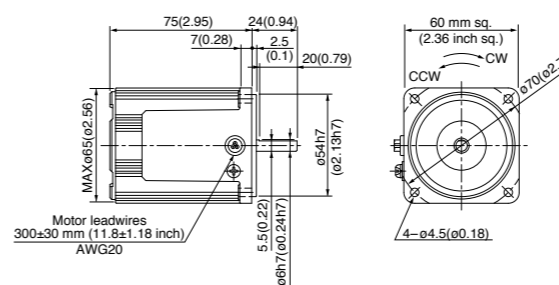

70 mm sq. (2.76 inch sq.) 15 W

Mass
1.1 kg (2.43 lb)

M71X15S4LS M71X15S4LG(A) M71X15S4YG(A)
M71X15S4YS M71X15S4DG(A) M71X15S4GG(A)

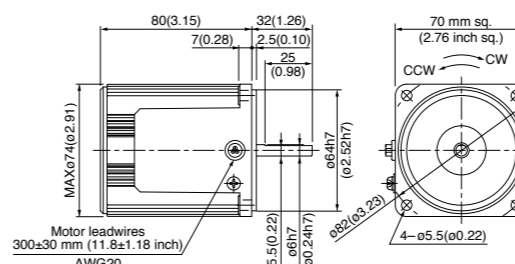

80 mm sq. (3.15 inch sq.) 25 W

Mass
1.5 kg (3.31 lb)

M81X25S4LS M81X25S4LG(A) M81X25S4YG(A)
M81X25S4YS M81X25S4DG(A) M81X25S4GG(A)

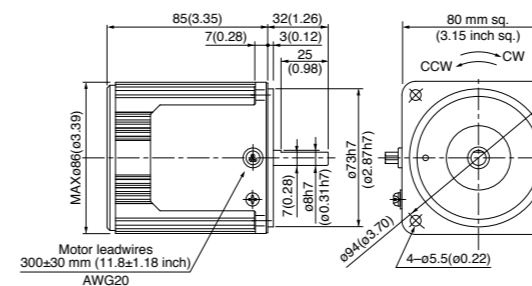

60 mm sq. (2.36 inch sq.) 3 W

Mass
0.56 kg (1.23 lb)

M61X3S4LS

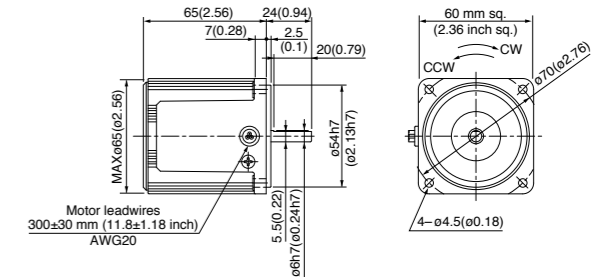

70 mm sq. (2.76 inch sq.) 10 W

Mass
0.84 kg (1.85 lb)

M71X10S4LS
M71X10S4YS

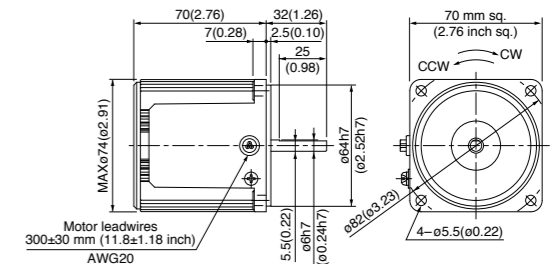

80 mm sq. (3.15 inch sq.) 15 W

Mass
1.2 kg (2.65 lb)

M81X15S4LS
M81X15S4YS

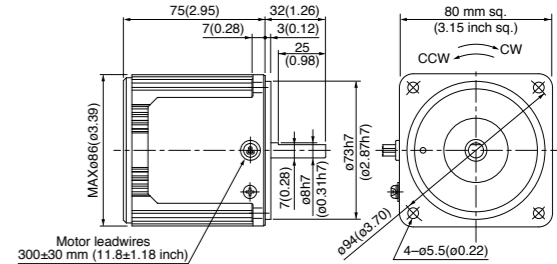

90 mm sq. (3.54 inch sq.) 40 W

Mass
2.4 kg (5.29 lb)

M91X40S4LS M91X40S4LG(A) M91X40S4YG(A)
M91X40S4YS M91X40S4DG(A) M91X40S4GG(A)

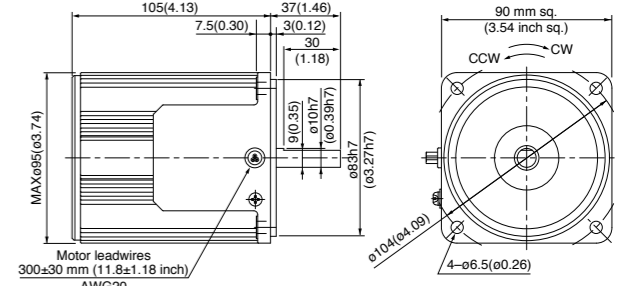

* Please refer to the pinion shaft motor for wiring and specifications of the motor.

(Note) Because the dimensions may be subject to change, also check the determinate dimensions if the gear head is to be used for design.

Specifications B-8 to B-57 Controls C-4 Option D-2

Induction motor Reversible motor 3-phase motor Electromagnetic brake motor Variable speed induction motor Variable speed reversible motor Variable speed electromagnetic brake single-phase motor Variable speed unit motor C&B motor 2-pole round shaft motor Gear head Gear head -inch (U.S.A.)

Induction motor (4-pole round shaft / leadwire)

Dimensions

Scale: 1/4, Unit: mm (inch)

90 mm sq. (3.54 inch sq.) 60 W Mass 2.7 kg (5.95 lb)

M91Z60S4LS (with fan) M91Z60S4LG(A) (with fan)
 M91Z60S4YS (with fan) M91Z60S4DG(A) (with fan)
 M91Z60S4YG(A) (with fan) M91Z60S4GG(A) (with fan)
 M91Z60S4GGB (with fan) M91Z60S4GGC (with fan)

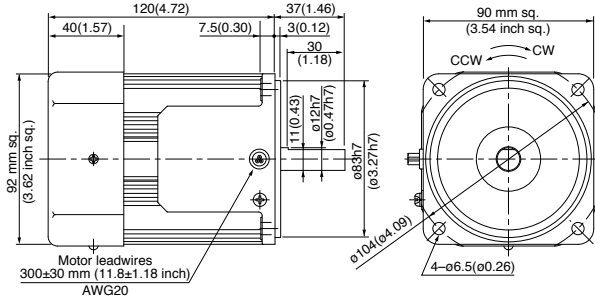

90 mm sq. (3.54 inch sq.) 90 W Mass 3.2 kg (7.05 lb)

M91Z90S4LS (with fan) M91Z90S4LG(A) (with fan)
 M91Z90S4YS (with fan) M91Z90S4DG(A) (with fan)
 M91Z90S4YG(A) (with fan) M91Z90S4GG(A) (with fan)
 M91Z90S4GGB (with fan) M91Z90S4GGC (with fan)

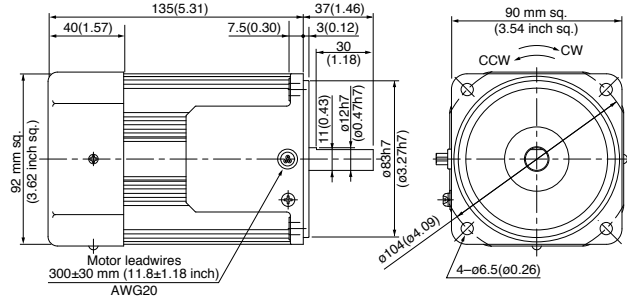

Induction motor (4-pole round shaft / sealed connector)

Dimensions

Scale: 1/4, Unit: mm (inch)

80 mm sq. (3.15 inch sq.) 25 W Mass 1.8 kg (3.97 lb)

M81X25SK4LS M81X25SK4LG(A)
 M81X25SK4YS M81X25SK4YG(A)
 M81X25SK4DG(A) M81X25SK4GG(A)
 M81X25SK4GGB(A) M81X25SK4GGC(A)

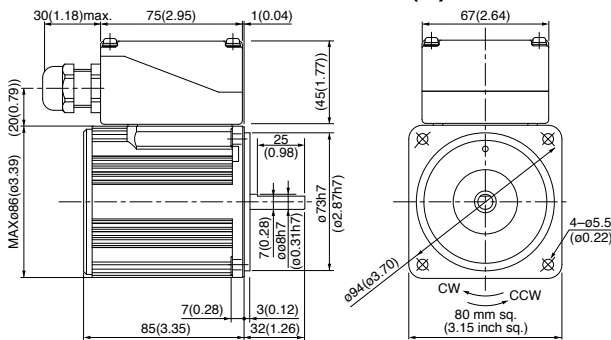

90 mm sq. (3.54 inch sq.) 40 W Mass 2.8 kg (6.17 lb)

M91X40SK4LS M91X40SK4LG(A)
 M91X40SK4YS M91X40SK4YG(A)
 M91X40SK4DG(A) M91X40SK4GG(A)
 M91X40SK4GGB(A) M91X40SK4GGC(A)

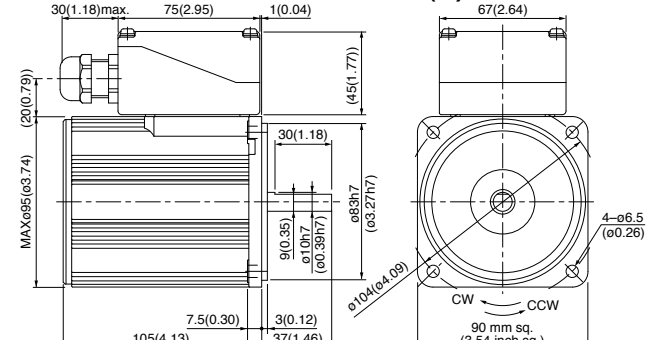

90 mm sq. (3.54 inch sq.) 60 W Mass 3.0 kg (6.61 lb)

M91Z60SK4LS (with fan) M91Z60SK4LG(A) (with fan)
 M91Z60SK4YS (with fan) M91Z60SK4DG(A) (with fan)
 M91Z60SK4YG(A) (with fan) M91Z60SK4GG(A) (with fan)
 M91Z60SK4GGB (with fan) M91Z60SK4GGC (with fan)

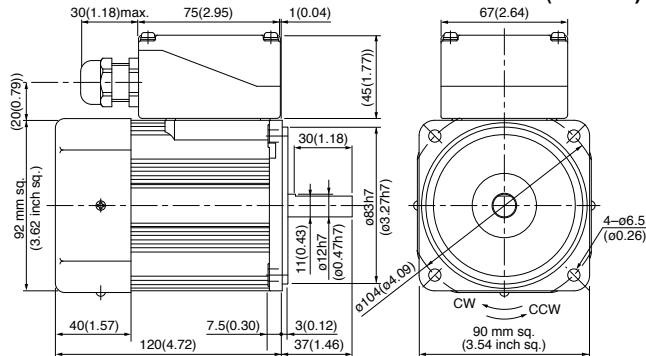

90 mm sq. (3.54 inch sq.) 90 W Mass 3.3 kg (7.28 lb)

M91Z90SK4LS (with fan) M91Z90SK4LG(A) (with fan)
 M91Z90SK4YS (with fan) M91Z90SK4DG(A) (with fan)
 M91Z90SK4YG(A) (with fan) M91Z90SK4GG(A) (with fan)
 M91Z90SK4GGB (with fan) M91Z90SK4GGC (with fan)

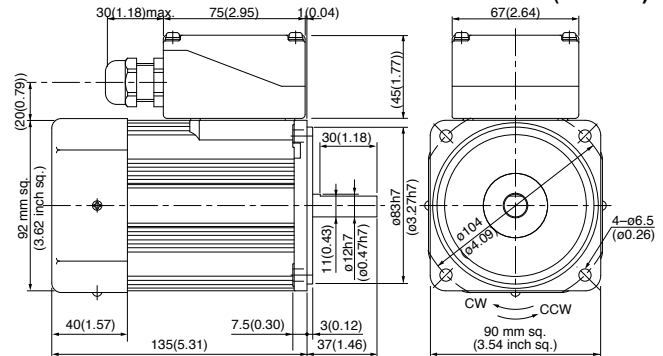

100 V/200 V round shaft motors with a sealed connector (with a terminal box) are covered by the Electrical Appliance and Material Safety Law. The indications on their nameplate are based on this law.

* Please refer to the pinion shaft motor for wiring and specifications of the motor.

* The models with a motor model number to which "A" or "B" is suffixed are not equipped with a capacitor cap.

* The models with a motor model number to which "A" or "B" is suffixed are not sold or available in Japan.

* Please read your User's manual carefully so that you will understand the operation and safety precautions before attempting to operate the system.

Features B-2

System configuration B-3

Coding system B-3

Model list B-4